

→ Series 682



■ MATERIAL



■ SPECIFICATION



DN 15 to DN 100    -20°C to +120°C

**Inlet pressure:**  
up to 40 bar  
**Outlet pressure:**  
0,5 to 15 bar  
depending on version

■ SUITABLE FOR

Liquids	neutral and non-neutral	
Air, gases and vapours	neutral and non-neutral	
Potable water cold	up to 40°C	
Potable water hot	up to 95°C	

■ EXAMPLES OF USE

For the protection of:

- domestic water supply systems
  - commercial and industrial plants
- against an excess supply pressure.

Pressure reducers are used, if within a piping system despite of varying pressures on the inlet side a certain pressure must not be exceeded on the outlet side.

- potable water supply according to DIN 1988
- process water supply in industrial- and building technology applications
- fire-fighting equipment and sprinkler systems
- shipbuilding industry and offshore plants

■ APPROVALS

<b>DIN-DVGW type examination (up to 80°C)</b>	
Type approval ACS	
Type approval WRAS (up to 85°C)	
Type approval PZH	
TR ZU 032/2013 - TR ZU 010/2011	
<b>Requirements</b>	
DIN DVGW guidelines DIN EN 1567 DIN 1988	DIN EN ISO 3822 DGR 2014/68/EU
<b>Classification society</b>	
DNV Lloyd's Register EMEA American Bureau of Shipping Bureau Veritas Russian Maritime Register of Shipping Registro Italiano Navale	DNV LR EMEA ABS BV RMRS RINA

■ MATERIALS

Component	Material	DIN EN	ASME
Inlet body	Gunmetal	CC499K	CC499K
Outlet body	Gunmetal	CC499K	CC499K
Inner parts, wetted	Gunmetal	CC499K	CC499K
	Stainless Steel	1.4404	316 L
Spring	Spring steel with anti-rust protection	1.1200	ASTM A228
Strainer	Stainless Steel	1.4404	316 L

<b>m</b>	with diaphragm	High-quality, heat-resistant moulded elastomere, fabric-reinforced diaphragm. Pressure adjustment by means of non-rising spindle. Valve insert with fully balanced seat, in sizes DN 15 up to DN 50 made of gunmetal and stainless steel, from DN65 up to DN100 made of stainless steel.
<b>k</b>	with piston	Stainless steel piston (only for DN 100) Adjustment by means of non-rising spindle. Balanced single seat valve.
<b>Complete valve cartridge SP/HP (order code: 482 Insert-DN..-seal) available as replacement part can be exchanged without removing the valve.</b>		
<b>Complete valve cartridge LP (order code: 482 LP Insert-DN..-seal) available as replacement part can be exchanged without removing the valve.</b>		
Built-in dirt trap made of stainless steel.		
Mesh size:	DN 15 to DN 32 DN 40 to DN 80	0,60 mm 0,75 mm

## ■ MEDIUM

<b>GF</b>	gaseous and liquid	for water, neutral and non-sticking liquids, compressed air and neutral gases; optionally with FPM elastomere seals for non-neutral media i.e. oils, fuels, oil-laden compressed air, etc. Not suitable with steam.
-----------	--------------------	---

## ■ TYPE OF LIFTING MECHANISM

<b>0</b>	without lifting device
----------	------------------------

## ■ OUTLET PRESSURE RANGES

<b>SP</b>	Standard version	Inlet pressure: up to 16 bar (PN 16) or 40 bar (PN 40)	Outlet pressure: from 1 to 8 bar
<b>HP</b>	High-pressure version (not for DN 65 and DN 80)	Inlet pressure: up to 16 bar (PN 16) or 40 bar (PN 40)	Outlet pressure: from 5 to 15 bar (5 to 13 bar, DN 100 with piston)
<b>LP</b>	Low-pressure version (not for DN 65, DN 80 and DN 100)	Inlet pressure: up to 16 bar (PN 16) or 25 bar (PN 40)	Outlet pressure: from 0,5 to 2 bar

## ■ AVAILABLE NOMINAL DIAMETERS AND CONNECTION SIZES

Nominal diameter DN	15	20	25	32	40	50	65	80	100
Inlet / Outlet	15/15	20/20	25/25	32/32	40/40	50/50	65/65	80/80	100/100
	■	■	■	■	■	■	■	■	■

## ■ TYPE OF CONNECTION INLET / OUTLET FLANGE CONNECTIONS

<b>FL / FL</b>	Standard	Flange connection / flange connection	DIN EN 1092 / DIN EN 1092
----------------	----------	---------------------------------------	---------------------------

## ■ SEALS

<b>EPDM</b>	Ethylene propylene diene	Elastomere moulded diaphragm and seals approvals according to drinking water directive	-20°C to +120°C (up to 8 bar outlet pressure) -20°C to +95°C (from 8 bar outlet pressure)
<b>FKM</b>	Fluorocarbon	Elastomere moulded diaphragm and seals	-10°C to +120°C (up to 8 bar outlet pressure) -10°C to +95°C (from 8 bar outlet pressure)

■ NOMINAL DIAMETERS, CONNECTIONS, INSTALLATION DIMENSIONS

Series 682: Connection, installation dimensions, ranges of adjustment											
Connection		DN15	DN20	DN25	DN32	DN40	DN50	DN65	DN65	DN80	DN100
		PN16 / PN40	PN16 / PN40	PN16 / PN40	PN16 / PN40	PN16 / PN40	PN16 / PN40	PN16	PN40	PN16 / PN40	PN16
Inlet pressure SP, HP up to	bar	16 / 40	16 / 40	16 / 40	16 / 40	16 / 40	16 / 40	16	40	16 / 40	16
Inlet pressure LP up to	bar	16 / 25	16 / 25	16 / 25	16 / 25	16 / 25	16 / 25				
Outlet pressure	bar	0,5 – 2	0,5 – 2	0,5 – 2	0,5 – 2	0,5 – 2	0,5 – 2	1 – 8	1 – 8	1 – 8	1 – 8
		1 – 8	1 – 8	1 – 8	1 – 8	1 – 8	1 – 8				
		5 – 15	5 – 15	5 – 15	5 – 15	5 – 15	5 – 15				
Installation dimensions in mm	D	95	105	115	140	150	165	185	185	200	220
	L	130	150	160	180	200	230	290	290	310	350
	H (H1)	102 (128 <sup>1</sup> )	130 (150 <sup>1</sup> )	130 (150 <sup>1</sup> )	130 (150 <sup>1</sup> )	165 (185 <sup>1</sup> )	165 (185 <sup>1</sup> )	235	235	235	320 (340 <sup>3</sup> )
	H2 (H3)	124 (150 <sup>2</sup> )	161 (181 <sup>2</sup> )	161 (181 <sup>2</sup> )	161 (181 <sup>2</sup> )	198 (218 <sup>2</sup> )	198 (218 <sup>2</sup> )				
	h	46	50	55	68	73	80	89	89	96	112
	K / nxd	65 / 4xM12	75 / 4xM12	85 / 4xM12	100 / 4xM16	110 / 4xM16	125 / 4xM16	145 / 4xM16	145 / 8xM16	160 / 8xM16	180 / 8xM16
Pressure gauge connections	G1							1/4" radial	1/4" radial	1/4" radial	1/4" axial
Inlet pressure											
Pressure gauge connections	G1	1/4" axial	1/4" axial	1/4" axial	1/4" axial	1/4" axial	1/4" axial	1/4" radial	1/4" radial	1/4" radial	1/4" axial
Outlet pressure											
Weight	kg	2,8 (3,1 <sup>1</sup> )	4,2 (4,6 <sup>1</sup> )	4,7 (5,1 <sup>1</sup> )	5,9 (6,3 <sup>1</sup> )	8,6 (9,3 <sup>1</sup> )	10,5 (11,2 <sup>1</sup> )	20	20	22	40 (43 <sup>3</sup> )
Coefficient of flow $K_{vs}^4$	m <sup>3</sup> /h	3	5,8	6,7	7,6	12,5	15	25	25	26	80

<sup>1</sup>for type 682mGFO-LP

<sup>2</sup>for type 682mGFO-LP S15

<sup>3</sup>for type 682kGFO-HP

<sup>4</sup>The  $K_{vs}$  value was determined according to DIN EN 60534-2-3. Instructions on how to determine size and capacity are to be found under section 2.

■ MAIN DIMENSIONS, INSTALLATION DIMENSIONS

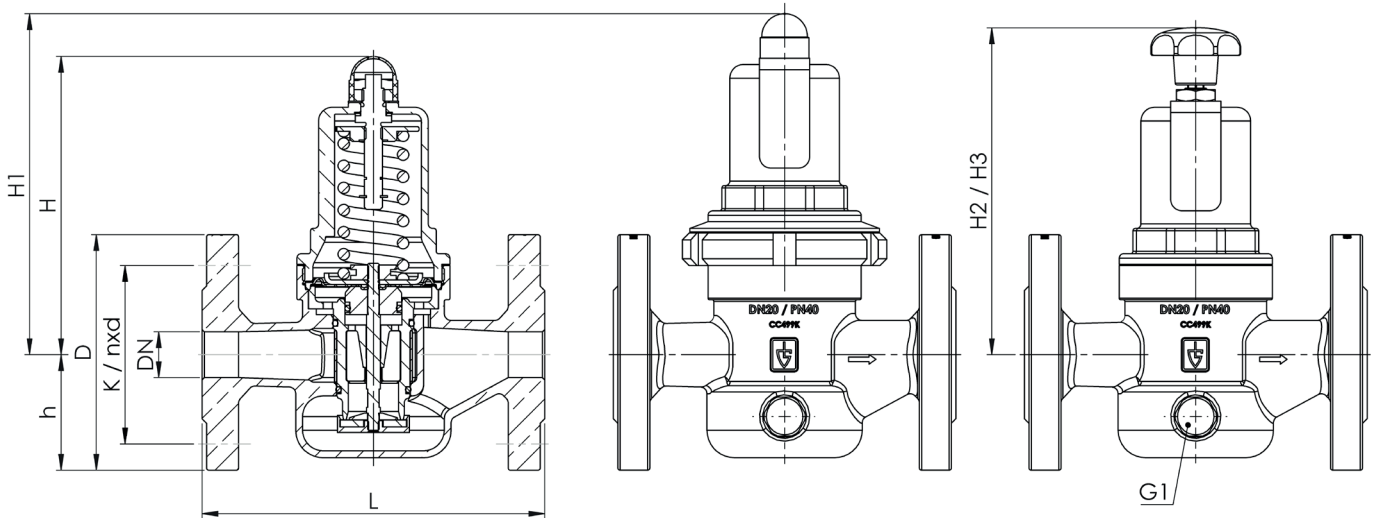

Series	Valve version	Medium	Lifting device	Outlet pressure	Nominal diameter DN	Connection type		Connection size		Seal	Options	Optional: fixed setting	Quantity
						Inlet	Outlet	Inlet	Outlet				
682	m	GF	0	HP	50	FL	FL	50	50	EPDM			5
682	k	GF	0	SP	100	FL	FL	100	100	FKM	S71	7	2
682		GF	0			FL	FL						
682		GF	0			FL	FL						

### ■ PROPERTIES

S15	Hand wheel (plastic) for tool-free setting of setpressure <sup>1</sup>	<input type="checkbox"/>		<input type="checkbox"/>
S17	Supply with manometers suitable for the valve finish	<input type="checkbox"/>		<input type="checkbox"/>
S71	Preliminary setup for protection against manipulation of the preset pressure (seal)	<input type="checkbox"/>		<input type="checkbox"/>

<sup>1</sup>For nominal diameters DN15 to DN50 outlet pressure ranges LP and SP

### ■ OPTIONS

GOX	Especially for gaseous O2 applications by employment of specific materials including oil- and grease free production process	<input type="checkbox"/>	P03	Galvanically nickel-plated finish	<input type="checkbox"/>
P01	Oil- and grease-free production	<input type="checkbox"/>	FE	Setting and sealing	<input type="checkbox"/>
P02	Chemically nickel-plated finish	<input type="checkbox"/>			<input type="checkbox"/>

### ■ CERTIFICATES / APPROVALS

C01	Factory certificate acc. DIN EN 10204 2.2 (WKZ 2.2)	<input type="checkbox"/>	C05	Sealing material Manufacturer certification (FDA, USP 3, 3-A,...), Please indicate description of certificate: .....	<input type="checkbox"/>
C02	Test certificate acc. DIN EN 10204 3.1 (WPZ 3.1)	<input type="checkbox"/>	C06	ATEX evaluation acc. to 2014/34/EU	<input type="checkbox"/>
C03	Material test certificate acc. DIN EN 10204 3.1 (MPZ 3.1) (pressure retaining part)	<input type="checkbox"/>	C10	Certificate of oil- and grease free production	<input type="checkbox"/>
C04	TÜV/DEKRA individual inspection acc. EN 10204 3.2 (TÜV/DEKRA-APZ)	<input type="checkbox"/>	C11	Certification of the production process especially for gaseous oxygen applications by employment of specific materials	<input type="checkbox"/>

### ■ ADMISSIONS / ACCREDITATIONS

AA1	EC Type examination acc. to Directive 2014/68/EU	<input checked="" type="checkbox"/>	AK1	Det Norske Veritas (DNV) type approval	<input type="checkbox"/>
AA4	EAC - certificate/declaration with passport for the valve and laser marking of the valve	<input type="checkbox"/>	AK2	Lloyd's Register (LR) type approval	<input type="checkbox"/>
AB1	Deutscher Verein des Gas- und Wasserfaches, DVGW type approval	<input type="checkbox"/>	AK3	American Bureau of Shipping (ABS) type approval	<input type="checkbox"/>
AB2	Water regulations and advisory scheme WRAS type approval	<input type="checkbox"/>	AK4	Bureau Veritas (BV) type approval	<input type="checkbox"/>
AB3	Attestation de Conformité Sanitaire, ACS type approval	<input type="checkbox"/>	AK5	Russian Maritime Register of Shipping (RMRS) type approval	<input type="checkbox"/>
		<input type="checkbox"/>	AK6	Registro Italiano Navale (RINA) type approval	<input type="checkbox"/>
		<input type="checkbox"/>	AL	Individual inspection by notified body inspector – (body to be indicated): .....	<input type="checkbox"/>

### ■ ENQUIRY

Copy and send to: [order@goetze-armaturen.de](mailto:order@goetze-armaturen.de).

Order form easily to be found online under the section for each series.

Series 682:

Dimensioning by pressure loss on the outlet pressure side

**Flow chart water**

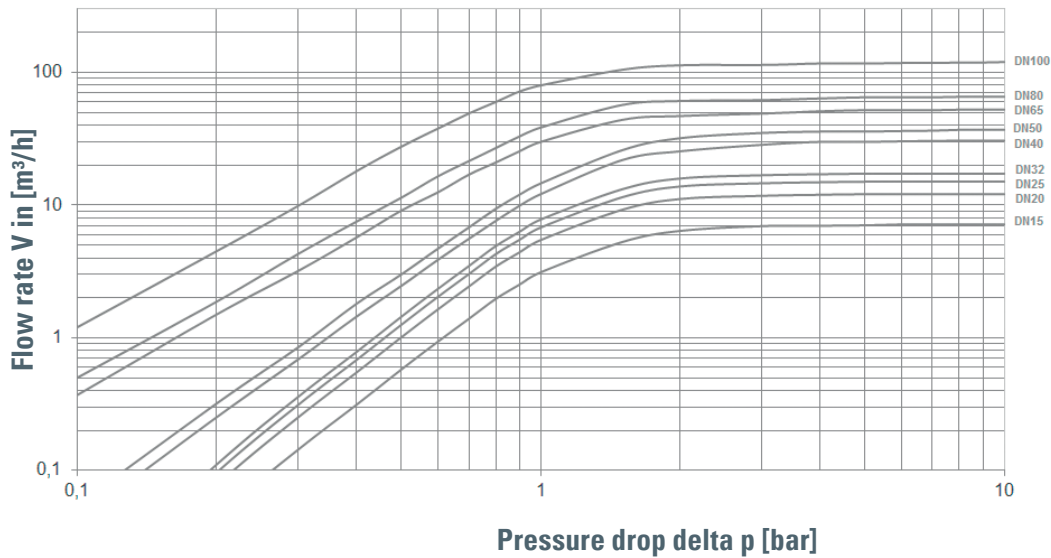

Dimensioning by flow velocity

**For liquids:**

With help of the chart you can determine the nominal diameter (DN) for a given flow volume V (m³/h). According to DVGW-guidelines (DIN 1988) a flow velocity of 2 m/s in domestic water supply systems should not be exceeded.

**For compressed air and other gaseous media:**

The usual flow velocity for compressed air is 10 - 20 m/s. For gaseous media the flow volume V should always be shown in actual cubic meters/hour. If the flow volume is given in standard cubic meters, these should be converted into actual cubic meters before using the diagram.

$$V(\text{m}^3/\text{h}) = \frac{V_{\text{Norm}} (\text{Nm}^3/\text{h})}{p_{\text{absolut}} (\text{bar})} = \frac{V_{\text{Norm}}}{p_{\text{U}} + 1}$$

Actual cubic meters are based on the prevailing pressure of the medium on the outlet side of the pressure reducer.

