



smartech

OILFIELD EQUIPMENTS & SPARE PARTS TRADING LLC

smart
technology
service



Catalogue

Drilling Products

BRIEF INTRODUCTION

SMARTECH TRADING LLC is a leading provider of equipments, services and solutions to the upstream and downstream in oil & gas industry. We are aimed at helping customers to obtain the maximum from their each well, Providing our customers superior quality at the best value for products and services in order to ensure our customers' continued satisfaction.

Our main range include but not limited below:

- 1). Rig packages: 250hp to 3000hp Land drilling rigs; Workover rigs (Fast-moving rigs are available).
- 2). Rig components: Crown block; Travelling block; Hook; Swivel; Rotary table; Drawwork; Driller's cabin; MCC/SCR house; MCC/VFD house; Top drive etc...
- 3). Wellhead & Pressure control equipments: BOP; Choke & Kill manifold; Pressure hoses; BOP closing unit; Casing & Tubing head; X-Mas tree; Valves; Spools and Flanges etc...
- 4). Solid control & Mud system equipments: Shale shaker; Desander; Desilter; Mud cleaner; Hopper; Centrifuge; Agitator; Mud tanks; Unions. etc..
- 5). Tubulars & Drilling strings: Drill pipe; HWDP; Drill collar; Kelly; Casing; Tubing; Pup joint; Sucker rod; Line pipes etc...
- 6). Tubular Running and Handling tools: Elevator; Slip; Manual/Power tong; HPU; Bushing; Spinner; Bit breaker; Spider; Links; Stabbing guide; Thread protector, Iron Roughneck, Fill and Circulate Tool Bucking unit etc...
- 7). Downhole/Fishing tools: Drilling & Fishing jar; Stabilizers; Hole opener; Overshot; Drill bit etc...
- 8). Cement tools: Cement unit; Float collar; Float shoe; Liner hanger; Cement head, Centralizer etc...
- 9). Others: Air winch; Drilling line; Safety equipments; Mud pump spare parts; Rig parts; Fittings etc...
- 10). Commissioning and other services.

Quality Control:

Quality admits no compromises. For this purpose, We exercise strict control on the starting from materials, We ensure our equipments are manufactured to the international standards, Producing per API, ISO or/and other applicable quality standards. We accentuate QA and QC monitoring & control processes to guarantee the quality, Our efforts is for providing the Customers with the peace of mind that when the equipment arrives on location, it is ready to go to work, and it will perform reliably.

After-Sales Service:

Our after sales service include equipment installation and rig up support, operational training, warranty interface, and supply of technical service and spare parts. Our highly skilled technicians travel worldwide to provide equipment training, commissioning and service, We are available in 24/7.

Our Mission:

Our mission is to provide our customers' superior quality at the best value for products and services with the active participation of all of our personal in order to ensure our customers' continued satisfaction.

Our Vision:

Our vision is to welcome and understand the requirements and necessities of the global work practices by building solid relationships with our partners for a lasting success. We would like to achieve continuous success through a multi-cultural organization by providing top quality services by abiding to ethical work conditions.

Your one stop source:

*From the crown to
the bit.*

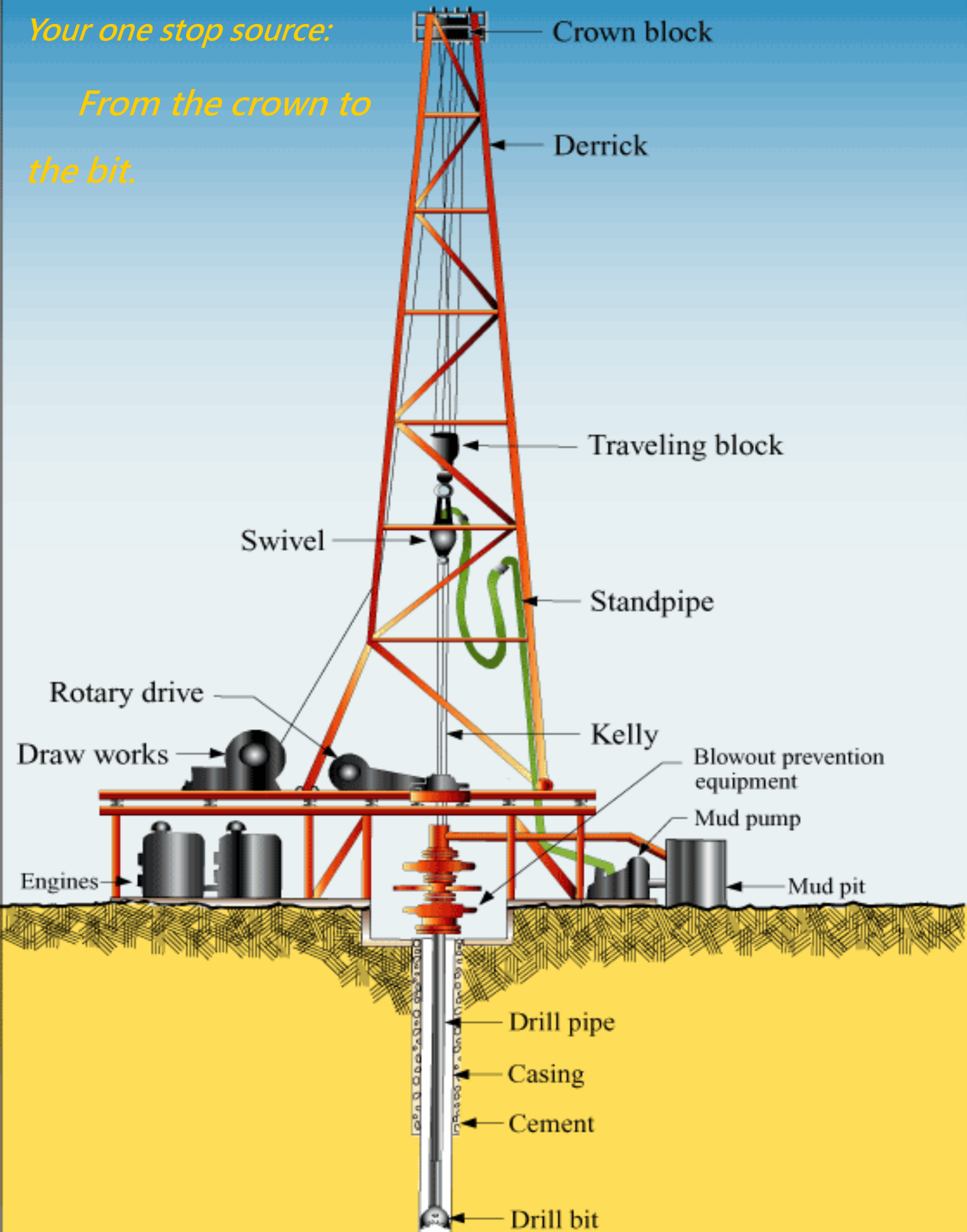

We provide the drilling & workover rigs from 350hp to 3000hp, driven by either traditional mechanical or modern SCR /VFD system, Available in design of truck-mounted or trailer-mounted and desert fast moving option.

The key components are from famous brands, such like CAT engines; Cameron/Shaffer well control equipments; Derrick/Mi-Swaco solid control equipments; Varco/Tesco/Canrig TDS; M/D Totco Instruments, etc...

Land Drilling Rig

Model		ZJ15	ZJ20	ZJ25	ZJ30	ZJ40	ZJ50	ZJ70
Normal drilling depth (4-1/2" DP)	m	1500	2000	2500	1600-3000	2500-4000	3500-5000	5000-7000
Dia. Of wire line	mm	φ 26	φ 29	φ 29	φ 29	φ 32	φ 35	φ 38
Height of derrick	m	31	31	31	32	43	45	45
Height of substructure	m	4.5	4.5/5	5	5/6	6/7.5	7.5/9	9/10.5
Max. Hook load	kN	1125	1580	1580	1700	2250	3150	4500
Rated weight of drilling string	kN	450	600	750	900	1200	1500	2100
Rated input power of Drawworks	kN	410	450	480	550	735	1100	1470
Opened Dia. Of Rotary table	mm	φ 444.5	φ 444.5	φ 444.5	φ 520	φ 698.5	φ 698.5 φ 952.5	φ 952.5



Workover Rig & Pulling Unit



Model		XJ250	XJ350	XJ450	XJ550	XJ650	XJ750	
Driving type of chassis		6×6	8×8	10×8	12×8 10×8	12×8	14×8	
Power of engine		bhp 300	350	475	475	600/700	2×525	
Rated hook load		kN 400	600	800	1000	1200	1500	
Max. hook load		kN 675	900	1100	1350	1580	1800	
Max fast pull of main drum		kN 120	180	196	210	210	280	
Max fast pull of sand drum		kN	105	105	105	105	105	
Working height of mast		m 21	31.6/29	32	33	35	38	
Height of racking board		m	20.6	20.6	20.6	20.6	21.7	
Substructure	Height of floor		2.5	3.4	4	4.5	4.5 or 5	6
	Area of floor		3×4	4×6	5×7	5×7	5×7	5×7
Traveling system from			3×4	3×4	4×5	4×5	4×5	5×6
Nominal overhaul well service depth (2 7/8" DP)		m	3200	4000	5500	7000	8500	8000

Crown Blocks



Design Features:

- The drilling line is reeved in parallel.
- The crown frame is made of high strength steel shapes & plates. The lug plate for top drive is provided. It is equipped with metal base plate, handrail. A ladder has an opening.
- The sheave cluster is tilted to counteract traveling block's torque. The side plate assembly is faced with derrick man for ease of picking off & suspending elevators.
- All sheaves have double-row conical roller bearings and each bearing has individual lubricating channel.
- Equipped with wooden bumper blocks and retainer net.
- Equipped with a frame crane for use in repairing the sheaves cluster.
- The sheaves and bearings are interchangeable with those of matching travelling block.
- The crown blocks conform to API Spec. 8A/4F and API monogram is per-

Model		TC135	TC170	TC225	TC315	TC450	TC585
Max. hook load	kN	1350	1700	2250	3150	4500	5850
O.D. of sheaves	mm (in)	915(36)	1005(40)	1120(44)	1270(50)	524(60)	1524(60)
Number of sheaves		5	6	6	7	7	8
Dia. of wire line	mm (in)	29 (11/8)	29 (11/8)	32 (11/4)	35 (13/8)	38 (11/2)	42 (15/8)

Travelling Blocks



Design Features:

- The side plate assembly is made of thick steel plate. When hoisting or lowering the unloaded elevators, the wire line is always kept taut to facilitate the line spooled on the drum and the empty hook lowered.
- The sheave grooves are intermediate frequency quenched so as to provide surface hardness and extended service life of wire line.
- Equipped with double-row conical roller bearings and each bearing has individual lubricating channel.
- The travelling blocks conform to API Spec. 8A/8C and API monogram can be used.

Model		YC90	YC135	YC170	YC225	YC315	YC450	YC585
Max. hook load	kN	900	1350	1700	2250	3150	4500	5850
O.D. of sheaves	mm(in)	762 (30)	915 (36)	915 (36)	1120 (44)	1270 (50)	1524 (60)	1524 (60)
Number of sheaves		4	4	5	5	6	6	7
Dia. of wire line	mm(in)	26(1)	26(1)	29(11/8)	32(11/4)	35(13/8)	38(11/2)	42(15/8)

Hooks



Design Features:

- The body, bail, and bail support are cast with special alloy steel.
- Equipped with a hydraulic snubber assembly to protect drill pipe joints when making up/breaking out connections.
- At the hook there is a reliable safety device.
- It is provided with a braking device to lock up & lock out the body.
- The primary-load-carrying parts of hook are subject to NDE test.
- The hooks conform to API Spec. 8A/8C and are stamped with API monogram.

Model		DG90	DG135	DG170	DG225	DG315	DG450	DG585
Max. hook load	kN	900	1350	1700	2250	3150	4500	5850
Major-hook opening	mm (in)	155 (61/16)	165 (61/2)	180 (7)	190 (71/2)	220 (85/8)	220 (85/8)	238 (93/8)
Diameter of Major-hook	mm (in)	116 (41/2)	140 (51/2)	150 (6)	160 (61/4)	180 (7)	180 (7)	180 (7)
Spring travel	mm (in)	180 (7)	180 (7)	180 (7)	180 (7)	200 (8)	200 (8)	200 (8)

Hook/Block Assembly

Design Features:

- Joining the travelling block and the hook together reduces overall length to satisfy the requirements of a top drive.
- The shafts of travelling block are forged with alloy steel and provided with a lubrication hole of bearing for one sheave.
- The grooves of sheave are intermediate frequency quenched so as to improve the surface hardness and prolong the service life of wire rope.
- There is a reliable safety device at the hook.
- The hook block assembly conforms to API Spec. 8A /8C and are stamped with API monogram.



Model		YG90	YG135	YG170	YG450
Max. hook load	kN	900	1350	1700	4500
O.D.of sheaves	mm (in)	762(30)	915(36)	915(36)	1524(60)
Number of sheaves		4	4	5	6
Diameter of wire line	mm (in)	26(1)	26(1)	29 (11/8)	38 (11/2)
Major-hook opening	mm (in)	155 (61/16)	165 (61/2)	180 (7)	220 (85/8)
Major-hook Dia.	mm (in)	116 (41/2)	140 (51/2)	150 (6)	180 (7)
Minor-hook Dia.	mm (in)	80 (31/4)	90 (31/2)	90 (31/2)	120 (43/4)

Swivel

Design Features:

- With standard bails and double pin alloy steel sub.
- The wash pipe and packing assembly are cartridge type and can be replaced on the floor without disconnecting the rotary hose and/or gooseneck.
- The gooseneck is provided with an outlet for wire line logging.
- With standard gooseneck joints. Threads are in compliance with API Std 5B.
- Conform to API Spec. 8A/8C and are stamped with API monogram.



Model		SL90	SL135	SL225	SL450	SL585
Max. static load rating	kN	900	1350	2250	4500	5850
Max. speed	r/min	300	300	300	300	300
Max. working pressure	MPa (psi)	25 (3570)	35 (5000)	35 (5000)	35 (5000)	35 (5000)
Hook clearance over gooseneck	mm(in)	435(171/8)	495 (191/2)	540 (211/4)	549(215/8)	584 (23)
Dia. of stem	mm(in)	64 (2 1/2)	64 (2 1/2)	75 (3)	75 (3)	75 (3)
Coupling Thread	To stem	4 1/2"	4 1/2"	6 5/8"	7 5/8"	7 5/8"
		REG LH	REG LH	REG LH	REG LH	REG LH
	To Kelly	6 5/8"	6 5/8"	6 5/8"	6 5/8"	6 5/8"
		REG LH	REG LH	REG LH	REG LH	REG LH

Rotary Table



Design Features:

- The split type master bushing is made from a steel casting. Two transmission types (Kelly and pin) are available.
- Pin transmission type is suitable for API standard square Kelly or hexagonal Kelly roller bushing. Long and short slips are applicable.
- With API casing bushings and special sling.
- Conform to API specification 7K and are stamped with API monogram.

Model		ZP175	ZP205	ZP275	ZP375	ZP495
Dia. of opening	mm (in)	444.5 (17-1/2)	520.7(20-1/2)	698.5 (27-1/2)	952.5 (37-1/2)	1257.3 (49-1/2)
Table axis to center inner row sprocket teeth	mm (in)	1118(44)	1353(531/4)	1353(531/4)	1353(531/4)	1651(65)
Max. static load	kN	1350	3150	4500	5850	7250
Max. working torque	Nm	14000	23000	28000	33000	37000
Max. speed	r/min	300	350	250	300	300
Gear ratio		3.58	3.22	3.67	3.56	3.93

3NB-Series Mud Pump



Design Features of 3NB-Series Mud Pumps:

- The power end: The housing is welded steel-plate construction. The drive gears are involute type gears which allow smooth operation, high efficiency and long life. The crankshaft is a hollow one-piece steel casting. The power end is either splash or pressure lubricated.
- The fluid end: The suction and discharge flanges conform to ASA and API specifications.
- The valve seat bores have a bottom shoulders. The pistons and liners are lubricated and cooled by an independently spraying pump to have a longer service life.

Model		3NB500C	3NB1000C	3NB1300C	3NB1600C
Power	KW(PS)	368 (500)	735 (1000)	956 (1300)	1176 (1600)
Strokes per minutes	pm	95	110	120	120
Stroke	mm	254	305	305	305
Gear ratio		3.82	3.833	3.81	3.81
Speed of driving shaft	r/min	363	423	457	457
Max. working pressure	MPa	30	35	35	35
Max .dia of liner	mm	160	170	180	190
Dia. of suction pipe	mm	254	305	305	305
Dia. of discharge pipe	mm	100	100	100	100

F-Series Triplex Mud Pump



F-Series Triplex Mud Pumps Design Features:

- F series mud pumps are in compliance with high technical specification and quality.
- F series mud pumps run smoothly and can meet the special requirements of customers during middle-deep drilling operations.
- It is small in size and reliable in operation. The suction valves and the discharge valves are interchangeable. And the main components of three cylinders and the fluid end modules are interchangeable.
- The fluid end modules of F series mud pumps have greatly improved the performance of triplex mud pumps. In addition, the unique design makes it easy to inspect quickly and to repair.

F-Series Triplex Mud Pump

Model		F-500	F-800	F-1000	FB-1300	FB-1600	FC-2200
Max. input horsepower	HP (kw)	500 (373)	800 (597)	1000 (746)	1300 (969)	1600 (1193)	2200 (1641)
Rated pump speed,	spm	165	150	140	120	120	100
Max. fluid cylinder liner bore	in. (mm)	6-3/4" (171)	6-3/4" (171)	6-3/4" (171)	7" (177.8)	7" (177.8)	8" (203)
Stroke	in. (mm)	7-1/2"(191)	9"(229)	10"(254)	12"(304.8)	12"(304.8)	15"(381)
Hydrostatic test pressure of standard fluid cylinders	psi (kg/cm ²)	7500 (527)	7500 (527)	7500 (527)	7500 (527)	7500 (527)	7500 (527)
Ratio of gears		4.38:1	4.31:1	4.32:1	4.31:1	4.3:1	4.27:1
Suction connection, ASA-150 lb. R. J. flange	in.	8"	10"	12"	12"	12"	-
Discharge connection cross w/API-5000-lb. R. J. flange	in.	4"	5"	5"	5"	5"	-

P-Series Triplex Mud Pumps

P-Series Triplex Mud Pumps Design Features:

- It is compact in construction, light in weight, small in area, and high in efficiency. All kinds of drive units can be provided as per different conditions.
- P series mud pumps run smoothly and can meet the special requirements of customers during shallow & middle-deep drilling operations.
- The fluid end modules of P series mud pumps have greatly improve the performance of triplex mud pumps. In addition the unique design makes it easy to inspect quickly and to repair.



Model		8-P-80	9-P-100	10-P-130	12-P-160	14-P-220
Overall length over skids	in. (mm)	161-5/8 (4105)	176-1/4 (4477)	186-5/8 (4740)	209 (5309)	218-1/4 (5544)
Width over frame	in. (mm)	62-9/16 (1589)	67-1/8 (1705)	71-3/8 (1813)	75-5/8 (1997)	91 (2311)
Width over pinion shaft	in. (mm)	93-7/8 (2384)	101-1/4 (2572)	107-1/4 (2724)	113-3/4 (2889)	125-3/4 (3194)
Height, floor to top of gear case	in. (mm)	60 (1524)	64 (1626)	67 (1702)	75 (1905)	84-1/4 (2139)
Height over fluid cylinders	in. (mm)	51-7/8 (1318)	54-7/8 (1394)	55-7/8 (1419)	62-15/16 (1599)	69-1/8 (1756)
Max. input horsepower	HP (kw)	800 (597)	1000 (746)	1300 (969)	1600 (1193)	2200 (1640)
Rated pump speed	spm	160	150	140	120	105
Max. fluid cylinder liner bore	in. (mm)	6 1/4 (158.8)	6 3/4 (171.5)	6 3/4 (171.5)	7 1/4 (184.2)	9 (228.6)
Stroke	in. (mm)	8 1/2 (215.9)	9 1/4 (235)	10 (254)	12 (304.8)	14 (355.6)
Ratio of gears		2.463	2.658	2.853	3.439	2.853
Suction connection, ASA-150 lb. R. J. flange	in.	8	8	8	10	10

Mud Pump Fluid end Parts and Expendables

Kingrig provides a full line of replacement parts for most popular mud pumps worldwide, Include but not limited below:

- F-350/500/800/1000/1300/1600/2200, FB-1300/1600
- TEE, PAH, PZ-7, PZ-8, PZ-9, PZ-10, PZ-11,PXL
- T-500/800/1000/1300/1600
- W-440, W-446, W-1612, WH-2214
- 7-P-50, 8-P-80, 9-P-100, 10-P-130, 12-P-160, 14-P-220



Power End Parts



- Bull gear • Pinion shaft • Bearing
- Crankshaft • Connecting & Extension rod
- Crosshead, Pin & Guide

Fluid End Module & Spare Parts

- . Fluid end module
- . Threaded ring
- . Lock cap
- . Cylinder head
- . Cylinder head plug
- . Valve cover
- . Valve guide
- . Liner retainer



- . Liner bushing . Liner clamp . Wear plate

Accessories & Tools



- Pulsation dampener • Bladder
- Discharge block • Pressure gauge
- Suction manifold • Relief valve
- Discharge manifold

Fluid End Expendables



- Liner • Liner gasket • Piston • Piston rubber • Valve & Seat
- Valve spring • Valve insert • Piston rod • Piston rod clamp

Mud Cleaner



The drilling liquid cleaner is fixed drilling liquid solids control equipment consisting of desander, desilter and shale shaker. It integrates the performance of aforesaid three equipments, featuring large disposal capacity, rapid treatment speed, less energy consumption, occupying small space, etc. It receives the most welcome in the international drilling market.

Model	ZQ300×2/100×12 Drilling liquid cleaner		
Desander parameters		Desilter parameters	
Cones	12"×2	Cones	4"×12
Working pressure	0.2~0.45 MPa	Working pressure	0.2~0.45 MPa
Capacity	240 m ³ /h	Capacity	200 m ³ /h
Separation point	40~74µm	Separation point	20~40µm
Inlet diameter	6"	Inlet diameter	6"
Outlet diameter	8"	Outlet diameter	8"
Shaker model	S220-3P / S240-3P / S280-3P		

Desander

As a solids control equipment of the second stage in drilling operation, desander is used to remove harmful solid particles of 40-74µm in drilling liquid. Suspending particles can be separated from the liquid under the centrifugal acceleration, by use of working principle of centrifugal subsidence.

Model	ZQJ300×2 / 1	ZQJ250×2 / 1
Cyclone conic cylinder diameter	300mm	250mm
Working Pressure	0.2~0.45MPa	0.2~0.45MPa
Capacity	240 / 120m ³ /h	200 / 100m ³ /h
Screen size	1240×585 mm	1240×585 mm
Screen spec	120-200 Mesh	120-200 Mesh
Inlet diameter	6"	6"
Outlet diameter	8"	8"
Power	0.5 kW	0.5 kW



Desilter

Desilter is used to remove solid particles of 20–40 µm in drilling liquid. The inlet and outlet of water cyclone can be connected very quickly, which is convenient for replacement and maintenance.

Model	ZQJ100×12	ZQJ100×16
Cyclone conic cylinder diameter	100mm	100mm
Pressure	0.2~0.45MPa	0.2~0.45MPa
Capacity	160-200 m ³ /h	200-240 m ³ /h
Inlet diameter	6"	6"
Outlet diameter	8"	8"
Power	0.5 kW	0.5 kW



Centrifuge Pumps

Centrifuge is the key equipment in treatment of harmful superfine solidoid in drilling liquid. It can separate and recycle the solidoid with the particle of bigger than 5µm and recover the density of drilling liquid so as to increase drilling speed. It is ideal drilling liquid purification equipment for drilling a deep well and a horizontal well. This equipment is mainly used to control density, viscosity of drilling liquid, minimize solidoid content in drilling liquid, clear away harmful solidoid and recover barite, and provide secondary recovery to swirler bottom in order to assure of excellent performance of drilling liquid and increase drilling speed.



Model	LW355×1280-N	LW450×1260-N	LW500×1000-N	LW500×1250-N
Diameter Revolving Drum(mm)	355	450	500	500
Length of Revolving Drum(mm)	1280	1260	1000	1250
Rate of Length versus Diameter	3.6	2.8	3	2.5
Maximum speed(r/min)	2500-3000	2400-3000	1600-1800	2400-2800
Separation Factor(Fr)	2035	2266	1100	2195
Capacity(m3/h)	10 - 20	30-40	40-60	35-50
Min separating point(µm)	2	2	5	3
Electric Engine Power(KW)	22+7.5	37+7.5	30+7.5	37+11

Mud Tank

Using the corrugated sheet structure, and with the “five stages purification, control of total access, total intrinsically safe circuit”, the mud circulation tank is well received by the drilling crew. The main features:

Model	MT-150	MT-160
Discharge capacity	200m3/h (7063ft3/h)	200m3/h (7063ft3/h)
Total capacity	1502m3 (5297ft3)	1602m3 (5650ft3)
Total power	220KW (270Hp)	190KW (255Hp)
Mud agitator	NJ-11, 9 SET	NJ-11, 9 SET
Sand pump	JSB8×6×14, 2 SET	SB8×6×14, 2 SET
Mud gun	NQ-80, 8 SET	NQ-80, 8 SET



Mud Gun



The function of mud gun is striking the sediment at the bottom of circulation tank with certain pressure which supplied by triplex pump or centrifugal pump, and then mixing the drilling liquid evenly by agitation of the agitator. It also can be used to wash the sand setting of the tank.

Model	NQ-80	NQ-50
Discharge capacity	55m ³ /h	50m ³ /h
Pressure	≤1 MPa	≤6.4 MPa
Adjustable range	0~330°	0~330°

Liquid-Gas Separator

Liquid—gas separator of drilling liquid is solids control equipment used to provide pre-degassing to gas cut drilling liquid. It is mainly used to clear away big bubbles of $\Phi 3-\Phi 25\text{mm}$. The liquid gas separator adopts bottom-sealing structure. It features simple structure, reasonable flow, big disposal capacity, high degassing efficiency, convenient transportation, installation and service, etc.



	1.0MPa			1.6MPa		4.0MPa	
	YQ-800-1	YQ-1000-1	YQ-1200-1	YQ-1000-1.6	YQ-1200-1.6	YQ-1000-4	YQ-1200-4
Diameter of the shell (mm)	800	1000	1200	1000	1200	1000	1200
Discharge capacity (m ³ /h)	260	300	320	300	320	300	320
Feeding pipe (mm)	150	150	150	152.4	152.4	150	150
Gas discharge pipe (mm)	200	200	200	203.2	203.2	200	200
Mud discharge pipe (mm)	250	250	250	254	254	250	250
Pressure (mpa)	1	1	1	1.6	1.6	4	4

Shale Shaker

The shale shakers were solely designed and manufactured by our company. The shale shakers being provided with high vibration intensity, adjustable-pitch, compact, reliable, behavior and cost effective.

Model	S280-3P	S240-3P	S220-3P	S180-2P
Motor power	2×2.2 kW	2×2.2 kW	2×2.2 kW	2×1.5 kW
Screen area(m ²)	2.8 m ²	2.4 m ²	2.2 m ²	1.8 m ²
Shaking intensity (g)	7.6 g	7.6 g	7.6 g	7.6 g
Discharge capacity	42 l/s	35 l/s	30 l/s	26 l/s
Adjustable range	-1°~+5.5°	-1°~+5.5°	-1°~+5.5°	-1°~+5.5°



Shaker Screens

Hook edge soft vibration screen:

Hook edge soft vibration screen has a same structure of plate type screen. The screen is usually made of two or three stainless steel meshes without metal backing. the area of soft screen is bigger than plate screen, and price is lower, but the service life is shorter. We can also make screens according to customer requirements.

Screen type	Mesh No.	Dimensions (L×W)	Shale shaker model
GMF-1	20-150	600×1040mm	Huayou NCS-300*2
GMF-2	20-150	700×1165mm	Huayou S250 Series
GMF-3	120-210	1400×460mm	Huayou ZCN Series
GMF-4	120-210	1000×1150mm	Huayou NS-115/2
GMF-5	20-80	927×914mm	JSS (U.S.A)
GMF-6	20-80	1219×1524mm	SSS(U.S.A)

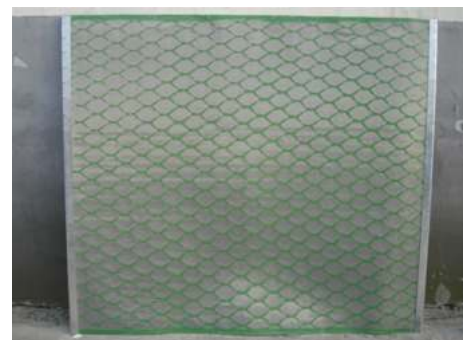

Awave vibration screen:

Awave vibration screen has an awave screen surface, Installation type can be hook edge or steel frame. the area of the awave screen is up to 125%-150% of the same area plate type screen, and the capacity increases a lot. We can also make screens according to customer requirements.

Screen type	Mesh No.	Dimensions (L×W)	Shale shaker model
GMB-1(PMD)	80-210	635×1253mm	BRANDT
			BL-50
GMB-2(PMD)	80-210	697×1050mm	DERRICR
			FLC 500 Series
GMB-3(PMD)	80-210	697×1053mm	DERRICR
			FLC2000
GMB-4(PMD)	80-210	915×1150mm	BRANDT
			LCM-ZD



Plate type vibration screen:

Plate type vibration screen is one of the most frequent vibration screen, and be used in all kind of drilling operation. The screen is made of two or three stainless steel meshes and metal backing with holes. We have a wealth of experience and mature technology in production, can also make screens according to customer requirements.

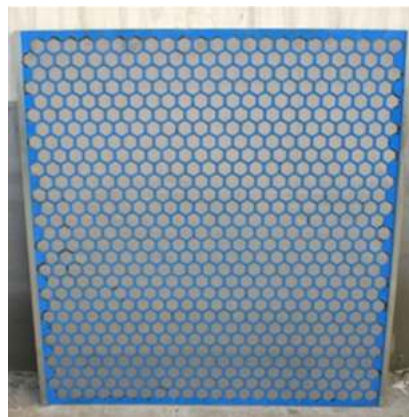

Screen type	Mesh No.	Dimensions (L×W)
GMP-1	16-325	903×1155mm
GMP-2	16-325	1212×1141mm
GMP-3 (PWP)	16-325	697×1050mm
GMP-4 (PWP)	16-325	697×1053mm
GMP-5	16-325	697×846mm
GMP-6 (PWP)	16-325	915×1150mm
GMP-7 (PWP)	16-325	720×1220mm
GMP-8 (PWP)	16-250	700×1165mm
GMP-9	16-250	1186×1280mm

Mud Agitator



Model	Power (KW)	Speed (RPM)	Impeller (MM)
WNJ7.5	7.5	1760	650/750
WNJ11	11	1760	800/700
WNJ15	15	1760	1000
WNJ22	22	1760	1000

Degasser



Menu	ZCQ1/4	ZCQ1/5
Capacity	m ³ /h 240	300
Working Pressure	MPa -0.03~-0.05	-0.03~-0.05
Efficiency	% 83	80
Power	Kw 15+3	37+7.5

Mixing Hopper



Model	HHQ-180
Capacity	200 M3/H
W. Pressure	0.2~0.4mpa
Power	55 KW
Clibing ability	≥3

Blowout Preventer (Annular BOP)



- The design and manufacture of Annular BOP is according to API Spec 16A standard.
- Packing element is spherical or tapered type with massive storage volume, low operation pressure and excellent sealing function.
 - Piston is set in low position to have a shorter moving distance; Use wear ring on piston.
 - Lip type seal rings are used to realize long service life.

Working Pressure (Psi)	Bore Size (in)				
	7-1/16	11	13-5/8	20-3/4	21-1/4
2000	--	--	--	--	√
3000	√	--	--	--	--
5000	√	√	√	√	--
10000	--	--	--	√	--
15000	--	--	--	--	--

Blowout Preventer (Ram BOP)

The Ram Blowout Preventer (BOP) is the most widely used. Its simple, compact design makes it well suitable for subsea or surface drilling operations. The Ram assembly provides a pressure-energized seal with maximum contact area to the drill pipe, casing, or tubing. This ensures a lower rubber pressure to the pipe and increase seal life.

- Type: Cameron U/ Shaffer LWS / Shaffer SL(Double and Single)
- Pressure rating, 2000PSI to 15000PSI
- Size Range: 7-1/16" to 21-1/4"
- Material, Forging / Casting
- Connection: Flanged/Studded/Hub
- Side outlets: Flanged / Studded / Hub
- Operations: Manual / Hydraulic
- Temperature, T-20

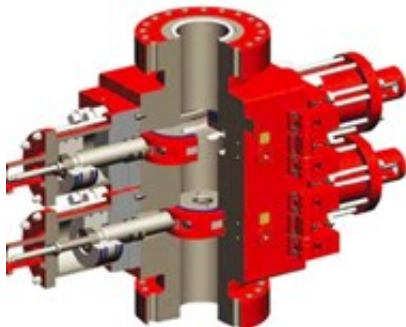
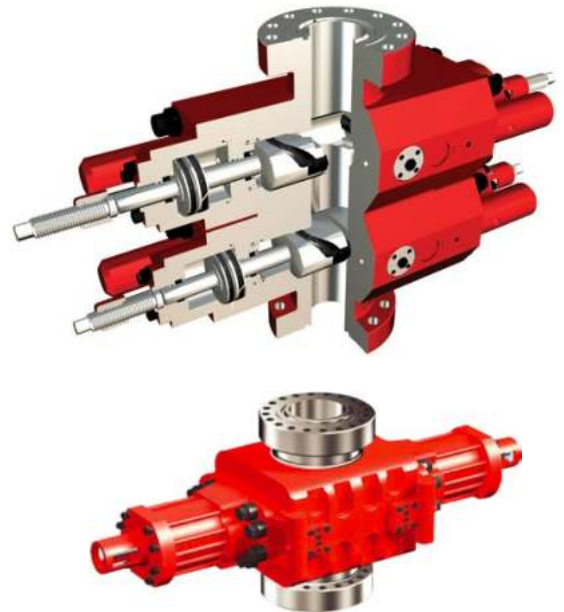

Working Pressure (Psi)	Bore Size (in)				
	7-1/16	11	13-5/8	20-3/4	21-1/4
2000	--	--	--	--	√
3000	√	--	--	--	--
5000	√	√	√	√	--
10000	--	--	√	√	--
15000	--	--	--	√	--

Choke Manifold

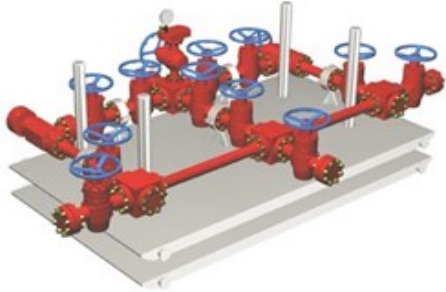

Choke manifold is the necessary device to control the well kick successfully and execute the pressure control technology on oil /gas well in the drilling. It is adopted to execute new drilling well's technique of balance pressure, which can prevent the pollution of oil-layer, improve the speed of drilling and control blowout effectively. One end to connect the side flange of BOP spool. When BOP closes, it can control the finite pressure from casing by adjusting the choke valve's opening, so balanced drilling can work under minimum pressure-difference. When the pressure rise in well, fluid in well can be released in utilization of the choke valve opening/closing in choke manifold to control casing pressure, which can directly blow out through gate valve as the casing pressure is quite high.

Pressure level is divided into five levels, i.e. 2,000psi, 3,000psi, 5,000psi, 10,000psi, 15,000psi; Fabrication of choke manifold is according to the requirements of API spec 16C. Working pressure: 2,000psi - 15,000psi; Nominal bore size: 2.1/16" to 4.1/16"



3,000 ~ 15,000PSI

Choke Manifold Control Console

Choke manifold control console as a control assembly in hydraulic choke manifold, can remote control the open / close of hydraulic choke valve for a long distance and the control panel can indicate the stand-pipe pressure, casing pressure and the opening / closing condition of hydraulic choke valve as well as the pulse number and frequency of the mud pump if pump-pulse counter equipped, which can keep the pressure under well and is a necessary device to control kick and blowout and perform the pressure control technology in oil / gas well.

Kill Manifold



In case of wellhead pressure increasing, the kill manifold can provide a means of pumping heavy drilling fluid into the well to balance bottom hole pressure so that well kick and blowout can be prevented. In this case, by using blow down lines connected to the kill manifold, the increasing well head pressure also can be released directly for bottom hole pressure release, or water and extinguishing agent can be injected into the well by means of the kill manifold. The check valves on the kill manifold only allow injection of kill fluid or other fluids into the well bore through themselves, but do not allow any backflow so as to perform the kill operation or other operations.

The one end of the kill manifold is connected to the drilling spool and the other end is connected to the pump. designed to API 16C and available from 14MPa, 21MPa, 35MPa and 70MPa pressure ratings.

Standpipe Manifold

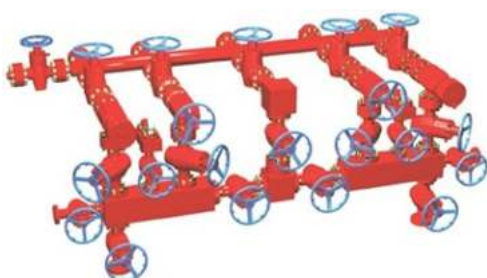

Vertical structure: could stand on deck with smaller occupation.
 Proper match: it is assembly of choke manifold and two sets of kill line, fabricated with two layers of drilling floor for easy operation.
 Full function: available with full function of the horizontal model manifold. The hard supporting frame is totally enclosed and corrosion prevention.
 Easy assembly: it is designed to combination with four components for ease of transportation.

BOP Closing Unit



Model	Station	Accumulators		Motor (HP)	Flow rate of pump			Working Pressure (psi)
		Total volume (Gallon)	Effective volume (Gallon)		Electrical pump (L/min)	Air pump (ml/stroke)	Manual pump (ml/stroke)	
FKQ1440-14	14	24x16.5	198	2x25	2x46	4x60		3000
FKQ1280-8	8	16x22	176	2x25	2x46	2x60		3000
FKQ960-8	8	16x16.5	132	2x25	2x46	2x60		3000
FKQ800-7	7	20x11	110	25	46	2x60		3000
FKQ720-6	6	12x16.5	99	25	46	2x60		3000
FKQ640-6	6	16x11	88	25	46	2x60		3000
FKQ480-5	5	12x11	66	25	35	2x61		3000
FKQ320-4	4	8x11	44	15	20	60		3000
FKQ240-4	4	6x11	33	15	20		14/28	3000
FKQ125-3	3	5x7	17.5	10	20		14/28	3000
FKQ125-2	2	5x7	17.5	10	20		14/28	3000

Casing Head and Casing Hanger

Casing head is to connect casings & wellheads. It is for supporting the weight of technical casing and production casing, sealing the annular space between the casings, and installing BOP stacks. It provides a transition joint for the tubing head, X-Mas tree and other wellheads. It can also supply cement, monitor & control well's sinking, and inject balance liquids etc by the two side outlets on the casing head housing.

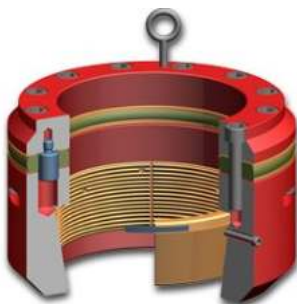
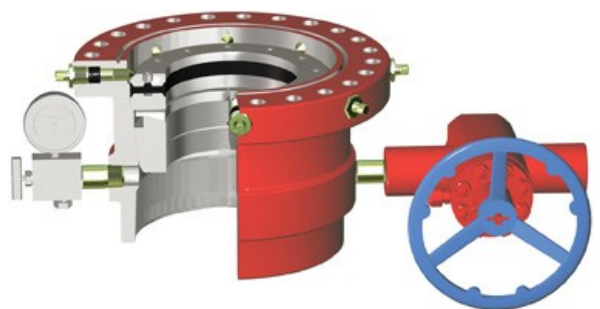

Casing hanger produced fits well with the casing housing, and the casing hanger of different sizes are available according to the casing procedure and the change of well head conditions. The standard casing head's top connection is API 6B or API 6BX flange.

Tubing Head and Tubing Hanger

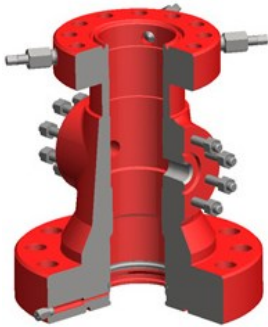

Tubing head is a usual spool with both flanged ends, which is set on the top flange of casing head to hang tubing hanger and seal the annular space between the tubing string and oil-layer casing and which consists of tubing head spool and tubing hanger.

Functions:

- 1) Hang the tubing string inside well;
- 2) Seal the annular space between tubing and casing;
- 3) Give a crossover to connect casing head downwards and to connect x'mas tree upwards;
- 4) Provide both side outlets in tubing head spool body through which to execute injection and well wash operation.

Tubing hanger is an assembly to support tubing string and seal the annular space between tubing and casing, which is connected with tubing and seated into tubing hanger spool by tubing gravity. It is convenient to operate and replace wellhead so that it is widely used for intermediate depth well and common well.

We manufacture tubing head spool in full accordance with API 6A, the body is made of forged or special smelt steel, providing high bearing strength, safety and reliability. Side outlets could be line pipe thread or studded, studded side outlet is machined with 1.1/2" female thread.

Christmas Tree

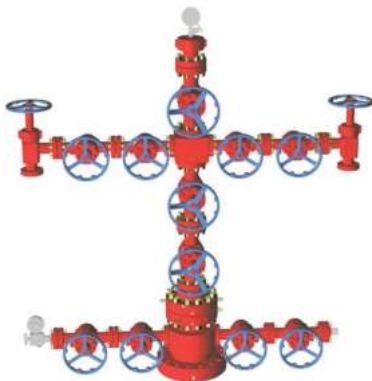

The Christmas tree is an assembly of valves, spools and fittings for an oil well, and to design to direct and control formation fluids from the well. It can provide inlet for production tubing strings, including all components above the tubing head adapter. Christmas tree assemblies can constitute many different kinds of combinations in order to meet any special requirement. Based on their different functions, Christmas trees can be classified into such special Christmas trees as oil production (flowing and artificial lift) Christmas trees, gas (natural gas and various sour gas) production Christmas trees, water injection Christmas trees, thermal recovery Christmas trees, fracturing Christmas trees and acidizing Christmas trees. Different pressure ratings serialize Christmas trees.

The gas production Christmas tree and tubing head are mainly used to produce gas and inject gas. The relative density of natural gas is low and gas column pressure is low, while well head pressure is high and liable to leakage regardless of gas production and gas injection. Sometimes natural gas contains corrosive media such as H₂S and CO₂. Therefore, the gas production Christmas tree calls for rigid requirements on both its materials and its sealing characteristics. For the sake of safety, two gate valves are used on the tubing and casing respectively. Some gate valves to be used on high pressure and ultra-high pressure gas wells are integrated valves manufactured from high quality forged steel.

Tees and Crosses



API 6A tees and crosses, include tees, 4-way, 5-way, 6-way crosses.
Pressure rating, 2000PSI to 15000PSI
Material classes. AA to FF
PSL 1 to 4 and PR 1 & 2

Chokes



Pressure rating, 3000PSI to 15000PSI
Size Range: 1-13/16" to 4-1/16"
Type: TLH (equivalent to H2)
Operations: Manual / Hydraulic
Material classes. AA to HH
Temperature, PU, LU
PSL 1 to 3 and PR 1 & 2
Available for Oil, Gas, H₂S, CO₂

Test Pump



Pressure test unit is widely used for high pressure testing of BOP stacks, choke and kill lines, Christmas tree and any other types of equipment requiring high pressure static testing. Ranging from 5,000 to 30,000 PSI of working pressure, such pressure test unit is available in unit-mounted, portable, skid-mounted and high flow electric driven styles. Accessories of pressure test unit, including stand-mounted chart recorders and high pressure BOP Accumulator Units, meet the design specification specified in API 16D. Customized pressure test pump is available to assure reliable control of the BOP stack with adequate reserve for continuous operation under emergency conditions.

Gate Valves:

Gate valves are available in temperature classes L, P, R, S, T, and U specified in API 6A. Fire-proof gate valves also can be supplied to API 6A. Working pressure are available from 2000psi to 15000psi, material classes from AA through FF, product specification levels (PSL) from 1 through 3 and performance requirement (PR) 1, 2.

Features:

- Simple structure and renewable gate and seat assembly.
- One-piece and double-acting gate with long service life.
- Both thrust bearings with large load capacity and composite rubber-plastic stem lip packing minimize operational torque.

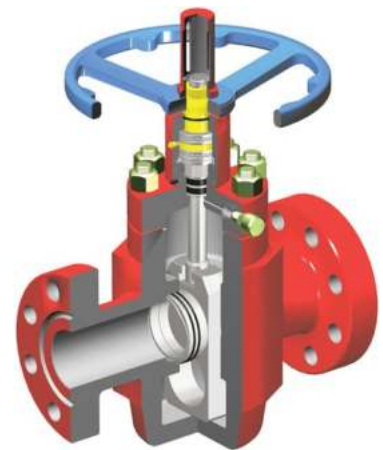

Mud Valves:

Our mud valve with reliability, safety, heavy load and corrosion resistance, which is used for a number of oilfield applications, including:

1. drilling standpipe manifold;
2. pump manifold block valves;
3. HP mud mixing lines;
4. HP drilling system block valve;
5. wellheads;
6. well treatment and fracture service;
7. production manifolds;
8. product gathering systems;
9. product flow line.

There are two models of sealing mechanism adopted in mud valve, that of metal to metal seal, and soft seal.



Butterfly Valve

Size: 2"~12"

Wafer type

Lug type



Check Valves

Check valve effects seal between valve cartridge and body by fluid pressure, the higher the fluid pressure, the better seal effected. The chamber could contain pressure in pipes all the time.

The body is made of forging alloy steel, with superior mechanical property, pressure endurance, safety and reliability.

Bonnet is connected with valve body with bolts. It has seals on bonnet and inner wall of body. Fitting space between bonnet and body is designed to zero so as to minimize loading on bolts and corrosive of bolts and holes.

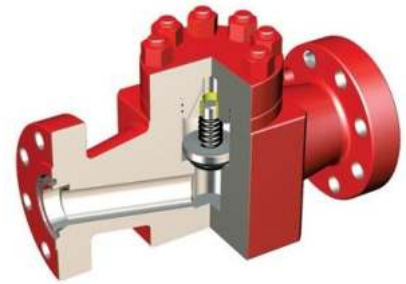

Carbide sealing surface has good anti-abrasion and corrosion resistance, the material of valve cartridge is fabricated of anti-sulfide steel, the other parts is made with hardness limiting method, the valve is suitable for H2S service.

Main Technical Parameters:

Working Pressure: 2,000 ~ 15,000psi

Nominal Bore Diameter: 2-1/16" ~ 7-1/16"

Working Medium: crude oil and natural gas.

Plug Valves

Plug valve is a necessary part that is applied to high pressure manifold in well cementing and fracture service, also selected for HP fluid control system. It is excellent for its compact structure, easy maintenance, low torque, and rapid operation.

The outlets of plug valve are FIG 1502 union connections (other connections on request), cylinder fits between body and wear bush, and seal rings are inlaid into outer of wear bush for good seal performance.

Main technical parameters:

Working Pressure: 2,000 ~ 15,000psi

Nominal Bore Diameter: 2" and 3"

Working Medium: crude oil and natural gas

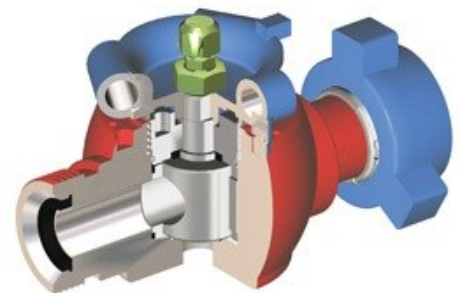

Unions

High pressure union is forged and made of high strength alloy steel with imported world-class technology. Strict heat treatment ensures uniform metallographic structure and bearing capacity in the connector. The materials used fully comply with ASTM and AISI, and the technical indices of the product with API standard. The product is tight and reliable, and provides easy mounting and dismantling and good exchange ability. The connector of the product allows for pipeline thread, oil tube thread and butt weld or pressureelsee seal end.

Size and Model:

Figure100, Figure200 ,Figure206, Figure211, Figure400, Figure300,

Figure600, Figure402, Figure1002, Figure602, Figure1003, Fig-



Hydraulic Power Unit

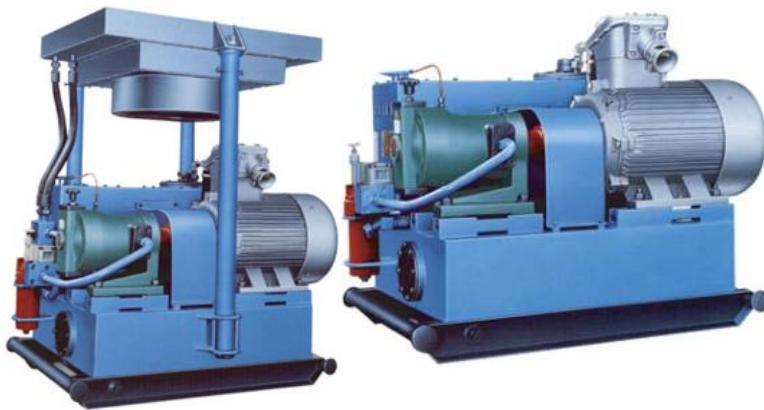

Hydraulic power unit mainly is to supply hydraulic source for power tong. It also can cooperate with other hydraulic equipments. The power unit features such advantages as wide adjusting range, convenient adjusting and high generality, etc.

Type: Electrical and Diesel type.

Motors are Ex-Proof type.

Water cooling and air cooling system is available.

Model		YZB-121	YZBS-120	YZBF-120	YZC-120 II
Rated flow	L/min	120	120	120	120
	gpm	31.7	31.7	31.7	31.7
Max. pressure	Mpa	20	20	20	20
	pai	2900	2900	2900	2900
Rated pressure	Mpa	16	16	16	16
	pai	2320	2320	2320	2320
Available capacity	L	587	587	587	600
	gal	155	155	155	158
Drive power	kW	37	37	37	60
	hp	49.6	49.6	49.6	80.4
Heating power	L		2x3	2x3	
	gal		2x4.02	2x4.02	
Fan motor power	kW			0.75	
	hp			1	
Radiation area	m ²		10water cooled	32	
	ft ²		107water cooled	344	

Drill Pipe Power Tong



Drill Pipe power tong is an ideal well head tool for oil drilling, widely applied for making-up and breaking-out in offshore and onshore drilling operations and well servicing operations. The drill pipe tong features safety, labor-saving, and high-efficiency. Open-throat design of the ZQ series allows the tongs to escape from drilling pipe freely with high mobility. The tong is a combination of spinning tong and torque tong. It substitutes cat-head, manual tong and rotary rope in making-up and breaking-out. The tongs are designed and manufactured according to industrial standard SY/T5074 and API Spec7K "Specification for Drilling Equipment"

Drill Pipe Power Tong

Model		ZQ127-25	ZQ127-25 Y	ZQ162-50	ZQ203-100	ZQ203-125	ZQ162-50 II	ZQ203-100 II	ZQ203-125 II
Size rang	Mm	φ65-127	φ65-140	φ85-162	φ127-203	φ127-203	φ85-162	φ127-203	φ127-203
	In	2 3/8"-3 1/2"	2 3/8"-5 1/2"	2 3/8"-5"	3 1/2"- 8"	3 1/2"- 8"	2 3/8"-5"	3 1/2"-8"	3 1/2"-8"
Max. torque	KN.m	25	25	50	100	125	50	100	125
	Ft.lbf	18440	18440	36880	73750	92200	36880	73750	92200
Speed (H)	rpm	65	65	60	40	40	60	40	40
Speed (L)	rpm	10.5	10.5	4.1	2.7	2.7	4.1	2.7	2.7
Air pressure	Mpa	0.5-1							
	psi	72-144							
Pressure rating	Mpa	12	16	16	16.6	20	16	16.6	20
	psi	1740	2320	2320	2400	2900	2320	2400	2900
Flow rating	L/min	120	120	114	114	120	114	114	114
	gpm	32	32	30	30	32	30	30	30
Shifting distance	Mm	1000	1000	1000	1500	1500	1000	1500	1500
	in	39.4	39.4	39.4	59	59	39.4	59	59

Casing Power Tong



Model		TQ178-16	TQ245-20Y	TQ340-35	TQ340-35Y	TQ356-55	TQ508-70Y	
Size rang	Mm	φ101.6-178	φ114.3-245	φ114.3-340	φ114.3-340	φ114.3-356	φ85-162	
	In	4"-7"	4 1/2"-9 5/8"	4 1/2"-13 3/8"	4 1/2"-13 3/8"	4 1/2"- 14"	9 5/8"-20"	
Max. pressure	Mpa	18	18	18	21	16.6	20	
	psi	2610	2610	2610	3045	2407	2900	
Working flow	L/min	110-160	110-160	110-160	110-170	110-160	110-170	
	gpm	29.3-42.7	29.3-42.7	29.3-42.7	29.3-45.4	29.3-42.7	29.3-45.4	
Air pressure	Mpa	0.5-0.9	--	0.5-0.9	--	0.5-0.9	--	
	psi	72-130		72-130		72-130		
Max torque	High gear	Kn.m	2.4-3	2.4-3	2.5-3	4.0-5.6	3.4-4.5	8.4-10.7
		Ft.lbf	1770-2210	1770-2210	1844-2210	2950-4130	2506-3319	6190-7890
	Middle gear	Kn.m	--	--	6.0-7.5	--	--	--
		Ft.lbf	--	--	4425-5530	--	--	--
Low gear	Kn.m	14.5-17.5	18-20	32-40	26-35.2	45-57.4	48.9-70.5	
	Ft.lbf	10694-12900	13270-14800	23600-29500	19175-25960	3319-42400	37244-52000	
Speed	Gear. H	Rpm	54-79	54-79	60-86	57-95	52-76	26-43.6
	Gear. M	Rpm	--	--	21-30	--	--	--
	Gear. L	Rpm	9-13.1	9-13.1	3.6-5.3	9-15	3.9-5.6	4-66

Tubing Power Tong

Tubing power tong (Inner curved cam clamp) is used for quick make-up/ break-out in well service operations.

The tong is equipped with hydraulic backup tong and use inner curved cam to clamp.



Model		XQ89/3YB,3YC,3YF	XQ89/3YE	XQ114/6YB	XQ140/12YA
Pipe Size Range Of Master Tong	mm	φ60-89	φ73-89	φ73-114	φ73-140
	in	2 3/8"-3 1/2"	2 7/8"-3 1/2"	2 3/8"-4 1/2"	2 7/8"-5 1/2"
Pipe Size Rang Of Backup Tong	mm	φ60-114	φ89-114	φ60-114.5	φ89-156
	in	2 3/8"- 4 1/2"	3 1/2"-4 1/2"	3 1/2"-5 1/8"	3 7/2"-6 1/8"
High Gear Rated Torque	kn.m	1.1	3	1.5	2.6
	ft.lbf	811	2213	1106	1918
Low Gear Rated Torque	kn.m	3	3	6	12
	ft.lbf	2213	2213	4425	8851
High Gear Rated Speed	r/min	90	28	85	72
Low Gear Rated Speed	r/min	30		20	14
Rated Operation Pressure	Mpa	10	10	11	12
	Psi	1450	1450	1595	1740
Max. Flow	L/min	80	90	100	120
	gpm	21	24	26	32

Sucker Rod Power Tong



Model		XQ28/1.8Y	XQ28/2.6Y
Pipe Size Range Of Master Tong	mm	Sucker rod 16,19,22,25 Tubing φ48-60	φ16,19,22,25, 28
	in	Sucker rod 5/8"-1 1/8" Tubing 1 7/8"-2 3/8"	5/8"- 1 1/8"
Pipe Size Rang Of Backup Tong	mm	Sucker rod 16,19,22,25,28 Tubing φ48-60	φ16,19,22,25, 28
	in	Sucker rod 5/8"-1 1/8" Tubing 1 7/8"-2 3/8"	5/8"- 1 1/8"
High Gear Rated Torque	kn.m	0.7	1
	ft.lbf	516	737.5
Low Gear Rated Torque	kn.m	1.8	2.6
	ft.lbf	1327.6	1918
High Gear Rated Speed	r/min	104	98
Low Gear Rated Speed	r/min	40	32
Rated Operation Pressure	Mpa	10	10
	Psi	1450	1450
Max. Flow	L/min	65	80
	gpm	17	21

Hydraulic Make-up and Break-out Unit

Hydraulic Make-up/Break-out Units is a kind of machine for making up and breaking out thread joint, which is suitable for assembly and disassembly of downhole pump, downhole tools, tubing, sucker rod, casing and other thread joint tools. This product has the following features:

- Units' head and backup tong clips or loosens simultaneously.
- Units' head and backup tong have four planetary claws with bi-direction clipping mechanism. Do not change any part in application range.
- Automatic Torque Control system can be provided according to the request of customers.
- The backup tong is equipped with hydraulic walking mechanism which can move with tube.
- Four speeds are available.

Model	YNJ160/15	YNJ200/15
Application Range	φ40-152 mm	φ60-195 mm
Rated High Gear Torque	1900ft-lbs	1900ft-lbs
Rated Low Gear Torque	11050 ft-lbs	11050 ft-lbs
HighGear Max. Speed	64 rpm	64 rpm
Low Gear Max. Speed	11 rpm	11 rpm
Rated System Sressure	2000 Psi	2000 Psi
Max. Oil Supply	120L/min	120L/min
Dimension L x W×H	3000×1300×1290 mm	3000×1300×1280 mm



Torque Control System

Torque control system is a torque measure & control equipment, matching with hydraulic power tong, make-up and break-out unit, etc.

No hydraulic oil is needed thanks to torque transducer adopted.

Make-up torque, parameters of pipe and coupler are set through Menu.

Laptop is equipped for a remote inspection.

Integrated electromagnetic relief valve can be equipped for a self-controlled make-up torque.

Make-up cyclomatic number can be recorded.

Make-up parameters are stored by means of daily re-port forms.

Reliable performance is applicable for severe environment of drilling.

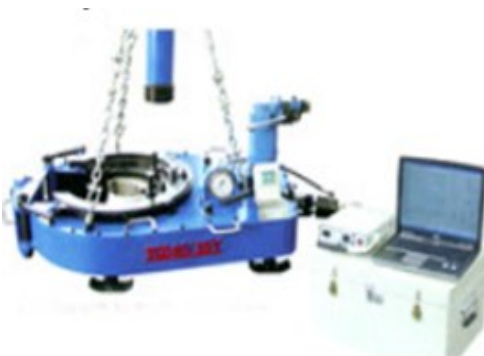

Rotary Slip

Varco design SDS, SDML, and SDXL Rotary Slips are for use in API standard insert bowls. Featuring better contact and distribution of load on drill pipe thru a superior wraparound configuration and unique insert design, these slips prevent bottlenecking and gouging damage. The buttress design of the body segments provides great strength while minimizing weight for ease of handling.



SDS-Short Rotary Slip

Slip Body size (inch)	3 1/2"			4 1/2"		
API pipe size (OD inch)	2 3/8	2 7/8	3 1/2	3 1/2	4	4 1/2
Parts No. slips c/w inserts	3901	3903	3905	3907	3909	3911
Weight. Slips c/w inserts lb (kg)	117 (53)	111 (50)	107 (48.5)	143 (65)	136 (62)	127 (58)
Qty of inserts	24	24	24	36	36	36
Weight of inserts lb (kg)	21 (9.5)	16 (7)	10 (4.5)	32 (14.5)	25 (11)	16 (7)

SDML-Medium Rotary Slip

Slips Body Size (inch)	3 1/2"			4 1/2"			5"			5 1/2"		
API pipe size (OD inch)	2 3/8	2 7/8	3 1/2	3 1/2	4	4 1/2	4	4 1/2	5	4 1/2	5	5 1/2
P/N Slips c/w inserts	15524	15523	15522	15563	15564	15565	15567	15568	15569	15571	15572	15573
Weight slips c/w inserts lb (kg)	193 (87.5)	188 (85)	180 (81.5)	207 (94)	199 (90)	188 (81.5)	204 (92.5)	196 (89)	185 (84)	200 (91)	185 (84)	181 (82)
Qty of inserts	30	30	30	45	45	45	45	45	45	45	45	45
Weight of inserts lb (kg)	26 (12)	22 (9.5)	13 (6)	39 (17.5)	31 (14)	20 (9)	39 (17.5)	31 (14)	20 (9)	39 (17.5)	31 (14)	20 (9)

SDXL-Extra Long Rotary Slips SDXL & SDL Inserts

Slips Body Size (inch)	4 1/2"			5"			5 1/2"		
API Pipe OD (Inch)	3 1/2	4	4 1/2	4	4 1/2	5	4 1/2	5	5 1/2
P/N slips c/winserts	15515	15514	15513	15518	15517	15516	15521	15520	15519
Weight slips c/w inserts lb (kg)	229 (104)	219 (99)	205(93)	237(105)	227(103)	213(96.5)	234 (106)	224 (101.5)	210(95)
Qty of inserts	54	54	54	54	54	54	54	54	54
weight of inserts lb (kg)	47(21)	37(17)	23(10.5)	47(21)	37(17)	23(10.5)	47(21)	37(17)	23(10.5)

Drill Collar Slip



Each segment of Varco design Drill Collar slips is a rugged drop forging, with an extra long back to provide maximum support to the circular button gripping elements. Full wrap-around design and circular buttons assure positive holding and slip setting. Drill Collar slips are flat on top to accommodate the MP Clamp.

DCS-Multi-segment Drill Collar slip

Slip Type	DCS-S		DCS-R		DCS-L					
	3-4	4- 4 7/8	4 1/2-6	5 1/2-7	6 3/4-8 1/4	8-9 1/2	8 1/2-10	9 1/4-11 1/4	11-12 3/4	12-14
Drill Collar OD (Inch)	3-4	4- 4 7/8	4 1/2-6	5 1/2-7	6 3/4-8 1/4	8-9 1/2	8 1/2-10	9 1/4-11 1/4	11-12 3/4	12-14
P/N slip c/w Circular Buttons	2572	2573	2552	2550	2503	2507	2530	2508	2534	2536
Weight, complete set, lb (kg)	112 (51)	103 (47)	120 (54)	112 (51)	154 (70)	173 (78)	185 (84)	198 (90)	213 (96)	207 (94)
Total number of segments	7	7	9	9	10	12	13	14	17	17
total number of intermediate segments	5	5	7	7	9	10	11	12	15	15
total number of hinge pins	6	6	8	8	10	11	12	13	16	16
use in insert Bowl Number	API or No.3				No.3		No.2		No.1	

DCS-Multi-segment Drill Collar slip

Slip type	DCS-S			DCS-R			DCS-L		
	P/N	lb	kg	P/N	lb	kg	P/N	lb	kg
Description	P/N	lb	kg	P/N	lb	kg	P/N	lb	kg
Segment- Right End	2568	11	5	2554	10	4.5	2510	12	5.5
Segment- left End	2569	11	5	2555	10	4.5	2511	12	5.5
Segment-Intermediate	2570	11	5	2556	10	4.5	2512	12	5.5
Hinge pin w/Cotter Pin	2525	-	-	2525	-	-	2520	0.7	0.3
Handle Pin w/ washer & Cotter Pin	3769	0.5	0.2	3769	0.5	0.2	3769	0.5	0.2
Handle for right & left end Segment	3765	3.5	1.5	3765	3.5	1.5	3765	3.5	1.5
Handle for intermedi- ate segments	3766	4	2	3766	4	2	3766	4	2
Retaining Cotter pin	71936	-	-	-	-	-	71936	-	-
Retaining screw w/lock washer	---	-	-	3748	-	-	-	-	-

DCS-Multi-segment Drill Collar slip

Slip set	Drill Collar OD (in)	P/N	Weight		Qty
			lb	kg	
DCS-S	3-4	2628-49	13	6	49
	4-4 7/8	2620-49	8	3.5	49
DCS-R	4 1/2-6	2628-63	16	7	63
	5 1/2-7	2620-63	11	5	63
DCS-L	6 3/4-8 1/4	2630-88	15	7	88
	8-9 1/2	2630-96	16	7	96
	8 1/2-10	2627-104	26	12	104
	9 1/4-11 1/4	2630-112	19	8.5	112
	11-12 1/4	2625-136	13	6	136
	12-14	2630-136	16	7	136

Casing Slip



Varco CMS-XL slips are designed to handle casing from 6 5/8" to 30 inches OD. All slips have an API taper of 4"/ft on the diameters. All CP-S slips (Conductor Pipe Slip) are furnished with 4 handles.

CSG Size	6 5/8"	7"	7 5/8"	8 5/8"	9 5/8"	10 3/4"	11 3/4"	13 3/8"	16"	18 5/8"	20"	24"	26"	30"
CMS-XL	5315	5301	5398	5305	5307	5309	5311	5313	5325	5333	5329	5331	5346	5342
CP-S												5338	5344	5340

CMS-XL

Description	P/N	Weight	
		lb	kg
Segment-Right end	5320	12	5.5
Segment --Left end	5321	12	5.5
Segment-Intermediate	5322	12	5.5
Hinge pin with Cotter Pin	2525	0.6	0.3
Handle pin with washer and cotter pin	3769	0.5	0.2
Handle for right and left segment	3765	3.5	1.5
Handle for intermediate segment	3766	4	2
Retaining screw with lock washer	3748	0.3	0.14

Circular Buttons for CMS-XL & CP-S slips

Pipe OD (inch)	24	26	30
P/N-Slip c/w Circular Buttons	5338	5344	5340
Weight c/w circular buttons lb (kg)	276 (125)	296 (134)	319 (145)
Total No. Segments	13	14	16
Total No. Hinge spacer	12	13	15

Circular Buttons for CMS-XL & CP-S slips

Slip set	Casing OD (in)	Circular Buttons			
		P/N	lb	kg	qty
CMS-XL	6 5/8	2628-144	36	16	144
	7	2619-144	36	16	144
	7 5/8	2630-144	24	11	144
	8 5/8	2630-156	26	12	156
	9 5/8	2630-168	28	13	168
	10 3/4	2630-180	30	14	180
	11 3/4	2627-204	51	23	204
	13 3/8	2630-216	36	16	216
	16	2631-252	43	19.5	252
	18 5/8	2626-300	60	27	300
	20	2631-312	52	23.3	312
	24	2631-360	60	27	360
	26	2631-396	64	29	396
	30	2631-444	72	32.5	444
CP-S	24	2631-156	26	12	156
	26	2631-168	28	13	168
	30	2631-192	32	14.5	192

Elevators



Pipe Size		Type	Cap. tons	weight	
inch	mm			lb	kg
18-Degree center latch Elevator G series					
2 3/8~5	60~127	MG	100	200	91
2 3/8~3 1/2	60~89	RGG	150	308	140
3 1/2~5 1/2	89~140	MGG	250	575	261
3 1/2~5 1/2	89~140	MGG AO	250	720	327
4~ 5 1/2	102~140	GG	350	715	324
4~5 1/2	102~140	GG AO	350	1018	463
4~ 6 5/8	102~168	HGG	500	1000	454
4~6 5/8	102~168	HGG AO	500	1500	680
18-Degree center latch elevator G Series w/ wear Bushing					
3 1/2~ 5 1/2	89-140	MGG	250	585	266
3 1/2~5 1/2	89-140	MGG AO	250	730	332
4~5 1/2	102-140	GG	350	725	329
4~5 1/2	102-140	GG AO	350	1028	468
4 1/2~5 1/2	114-140	HGG	500	1010	459
5~ 6 5/8	127-169	HGG	500	1010	459
4 1/2~5 1/2	114-0140	HGG AO	500	1500	685
5-6 5/8	127-168	HGG AO	500	1500	685
Bottleneck Center Latch Elevator					
4~5 1/2	104-140	BNC	350	880	400
Collar Type Side Dollr Elevator					
1.660~2 7/8	42~73	SLX	65	50	23
2 3/8~2 7/8	60~73	SLX	100	75	34
3 1/2~4	89~102	SLX	100	105	48
4 1/2~5 1/2	110~140	SLX	100	175	79
5 1/2~8 5/8	140~219	SLX	150	325	147
9 5/8~10 3/4	245~273	SLX	150	420	191
11 3/4~13 3/8	298~340	SLX	150	500	227
16	406	SLX	150	575	261

Pipe Size		Type	Cap. tons	weight	
inch	mm			lb	kg
Collar Type Side Dollar Elevator					
18 5/8~20	473~508	SLX	150	700	318
26~30	660~762	SLX DD	150	1320	600
6 5/8~7 5/8	168~194	SSD	250	600	273
8 5/8~10 3/4	219~273	SSD	250	620	282
11 3/4~14	298~356	SDD	250	635	289
18 5/8~20	473~508	SX	250	1100	499
22~24 1/2	559~622	SLX	350	1000	454
9 5/8~13 3/8	244~340	SX	350	1200	544
9 5/8~13 3/8	244~340	SX	500	1100	499
16	406	SX	500	1200	544
Collar type center latch Type Elevator					
1.050~2 1/2	27~73	TA	35	39	18
1.660~ 2 7/8	42~73	TA	65	65	29
3 1/2~4 1/2	89~114	TA	65	83	38
2 3/8~2 7/8	60~73	TA	100	100	45
3 1/2~5	89~127	TA	100	158	72
4 3/4~8 5/8	121~219	TA	100	410	186
4 1/2~8 5/8	114~219	TA	150	430	195
4 3/4~8 5/8	121~219	TA AO	150	530	240
8 1/2~11 1/4	216~289	TA	150	430	195
8 1/2~11 1/4	216~289	TA AO	150	550	250
2 3/8~4 1/2	60~114	RGA	200	162	73
3 1/2~7	102~178	GA	350	555	252
3 1/2~7	102~178	GA AO	350	725	330
7~7 5/8	178~194	GGA	350	695	316
7~7 5/8	178~194	GGA AO	350	998	354

Manual Tong

Manual tong are offered in torque ranges from the lightweight small 16,000 lb-ft to the larger and more rugged 100,000 lb- ft .Each tong features tough, heavy- duty designs with heat-treated hinge pins and long-lasting "stagger tooth" tong dies (Blue Diamond, Pyramid).

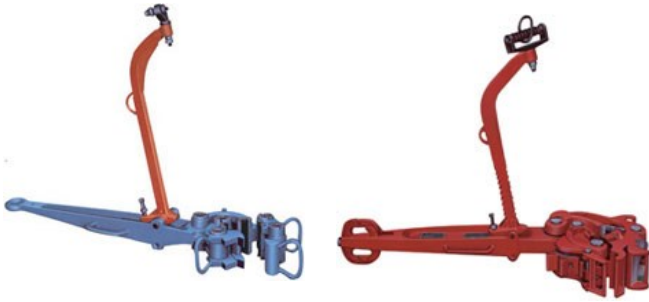

Model	Jaw Size (inch)	Torque rating (lb-ft)
KRMT75-SDD	12~15	75,000
KRMT60-SDD	16 ~ 17	60,000
KRMT65-DB-HT65	3 1/2 ~ 11 1/4	65,000
KRMT40-DB	11 3/4 ~ 17	40,000
KRMT55-B-HT55	3 3/8 ~ 9	55,000
KRMT40-B	9 ~ -11 3/4	40,000
KRMT25-B	13 3/8 ~ 30	25,000
KRMT25-C	2 3/4 ~ 10 3/4	25,000
KRMT16-SLF	2 3/8 ~ 8 5/8	16,000

The blue diamond die offers superior performance by providing better utilization of its unique gripping surface. The tech are crowned at the middle of the die, rather than being the same height along its full length. This crowned profile reduces end loading and assures a quick, positive (but gentle) grip under all torque loads. The results are greater efficiency and longer wear, with less marking and scarring of pipe. As a bonus feature, all dies are heat-treated with a special process that assures uniform tooth hardness long life.

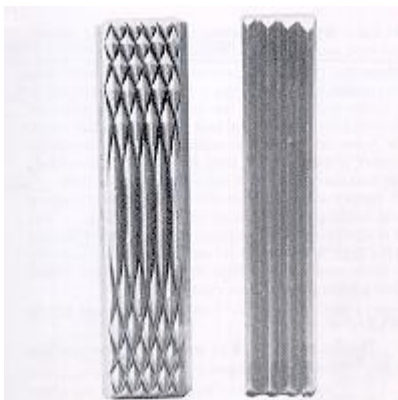

Tongs	Die Type	P/N	Size		Weigh per doz	
			in	mm	lb	kg
BJ Tongs	Blue dia- mond	16402-6	1/2 x 1 1/4 x 5 7/8	12.7 x 31.75 x 149.22	9	4.08
BJ DB made in 1965 and later	Pyramid	16402-2	1/2 x 1 1/4 x 5 7/8	12.7 x 31.75 x 149.22	9	4.08
BJ SDD, C, F and LF	Blue Dia- mond	16401-6	1/2 x 1 1/4 x 5	12.7 x 31.75 x 127	6.75	3.06
Short dies for BJ Type B tong with 1 1/4" slot	Pyramid	24768	1/2 x 1 1/4 x 3 7/8	12.7 x 31.75 x 98.42	6	2.72

Bushing

Master Casing Bushing



Master casing bushing selection chart

	Size	MPCH		MSPC		MSP/MDSP
		Complete	Body Only	Complete	Body Only	Complete
API Standard	27 1/2	-	-	1804-1	1808-1	5429-1
EMSCO	T-2750	-	-	1804-1	1808-1	5429-1
	G-27 1/2	-	-	1804-5	1808-5	5429-5
	H-27 1/2	-	-	1804-2	1808-2	5429-2
	K-27 1/2, KS, P1	-	-	1804-3	1808-3	5429-3
	T-3750 (S/N 1-48)	6600-2A	6601-2A	-	-	-
	T-3750/4950 (49 /UP)	6600-2	6601-2	-	-	-
Garnder Denver	RT 27 1/2	-	-	1804-1	1808-1	5429-1
	RT 37 1/2	6600-7	6601-7	-	-	-
IDECO	27 1/2	-	-	1804-7	1808-7	5429-7
	37 1/2	6600-4	6601-4	-	-	-
National	MS 27 1/2, A & B 27 1/2	-	-	1804-5	1808-5	5429-5
	C-365	6600-5	6601-5	-	-	-
	C-375	6600-1	6601-1	-	-	-
Oilwell	A-27 1/2	-	-	1804-1	1808-1	5429-1
	A-37 1/2	6600-3	6601-3	-	-	-
Wirth	27 1/2	-	-	1804-1	1808-1	5429-1
	37 1/2	6600-3	6601-3	-	-	-

MPCH Casing Bushing

The 37 1/2" MPCH is a Pin Drive Hinged Master Bushing specially designed for floating and semi-submersible drilling operations.

With insert bowl No. 3 and optional insert bowls No. 1 and No. 2, the MPCH will handle tubulars from 2 3/8" to 13 3/8" OD. Unit comes complete with No. 3 insert bowl, bit breaker adapter plate and lifting sling.



For use with Rotary Table

	table sizes	w/No.3 Bowl, sling & BB Adapter			w/o No.3 Bowl, sling & BB Adapter		
		P/N	Weight		P/N	Weight	
			lb	kg		lb	kg
EMSCO	37 1/2 (S/N 1-48)	6600-2A	4325	1962	6601-2A	3325	1508
	37 1/2 (S/N 49 up 49 1/2)	6600-2	4149	1882	6601-2	3149	1428
Oilwell	37 1/2 to 49 1/2	6600-3	4245	1925	6601-3	3245	1472
IDECO	37 1/2	6600-4	4015	1821	6601-4	3015	1367
National	36 1/2	6600-5	3910	1773	6601-5	2905	1318
	37 1/2 to 49 1/2	6600-1	4029	1827	6601-1	3029	1374
Wirth	37 1/2 to 49 1/2	6600-6	4245	1925	6601-6	3245	1472

MDSP Casing Bushing

17-1/2" and 20-1/2" Medium Duty Pin Drive Split Master Bushing are designed for shall low to medium depth service. Extended API Taper
The MDSP Master Bushings have an extended APT taper in the bowls that provides 50 % more slip support than do square drive bushings.
Varco SDML slips, used in the MDSP master bushing are a proven combination that can handle drilling to 15,000 feet.



Note : Varco BJ does not recommend using split master bushings in rotary tables with more than 3/16" (5 mm) wear in the rotary table bore. Rebuild rotary bore or purchase a solid type bushing.
Units come complete with bit breaker, adapter plate and lifting sling.

MPCH Parts

	Rotary Table sizes	w/sling & BB Adapter			w/o Sling & BB Adapter		
		P/N	weight		P/N	weight	
			lb	kg		lb	kg
API	17 1/2	70517-1	737	334	70526-1	577	262
	20 1/2	70540-1	1100	499	70539-1	924	419
Bethlehem	17 1/2	70527-2	737	334	70526-2	577	262
	B175	70527-3	737	334	70526-3	577	262
	B-210 (5-in flange)	70540-2	1100	449	70539-2	924	419
	B-210 (5 1/2 in flange)	70540-3	1100	449	70539-2	924	419
Brewster	OB-18 & RSH-18	70527-4	737	334	70526-4	577	262
Continental	T1750	70527-1	737	334	70526-1	577	262
Emsco	L-17	70527-5	737	334	70526-5	577	262
	O-17 1/2 & P-17 1/2	70527-6	737	334	70526-6	577	262
	T2050	70540-4	1100	449	70539-4	924	419
	20 1/2, O, P, PJ, J, JA, JC, JAC, JACS, JAS, JCS, & JS	70540-5	1100	449	70539-5	924	419
Gardner Denver	20 1/2, JAB, JABS, JB, & JBS	70540-6	1100	449	70539-6	924	419
	RT- 17 1/2	70527-1	737	334	70526-1	577	262
Haniel & Lueg	L- 17 1/2	70527-1	737	334	70526-1	577	262
Ideco	17 1/4	70527-7	737	334	70426-7	577	262
	17 1/2 & HS-175	70527-8	737	334	70526-8	577	262
	20 1/2	70540-1	1100	449	70539-1	924	419
National	17 1/2, A175, & B-175	70527-9	737	334	70526-9	577	262
	A205 & 20 1/2	70540-4	1100	449	70539-4	924	419
Oilwell	A 17 1/2	70527-10	737	334	70526-10	577	262
	17 1/2	70527-11	737	334	70526-11	577	262
	A 20 1/2	70540-4	1100	449	70539-3	924	419
	20 1/2	70540-7	1100	449	70539-7	924	419
	21 & 21 A	70540-8	1100	449	70539-8	924	419

Safety Clamp

MP Multi-Purpose Safety Clamp



The MP Multi-Purpose Safety Clamp provides safe handling of all types of flush joint pipe, liners, and drill collars during make-up, break-out and setting through the rotary table. The MP Clamp can act as a shoulder elevator, if needed, or fitted with lifting eyes to handle large diameter pipe. This versatile tools can also be inverted and fitted with hold own lugs for use in all types of snubbing operations. For maximum durability and long life in the field, interchangeable handles, lifting eyes and hold own lugs are forged, heat-treated steel.

Model	Rang (inches)	P/N	Qty			
			Links	Gripping Dies	lb	kg
MP-S	2 7/8"-4 1/8"	33030	7	8	83	37.5
	4"-5"	33031	8	9	91	41
MP-R	4 1/2"- 5 5/8"	33011	7	8	81	37
	5 1/2"-7"	33012	8	9	89	40
	6 3/4"-8 1/4"	33013	9	10	97	44
	8"-9 1/4"	33014	10	11	105	47.5
	9 1/4"-10 1/2"	33015	11	12	113	51
MP-M	10 1/2"-11 1/2"	33016	12	13	121	55
	11 1/2"-12 1/2"	33017	13	14	129	58.5
	12 1/2"-13 5/8"	33018	14	15	137	62
	13 5/8"-14 3/4"	33019	15	16	145	66
	14 3/4"-15 7/8"	33020	16	17	153	69.9
MP-L	15 7/8"-17"	33021	17	18	173	78.5
	17"-18 1/2"	33022	18	19	181	82
	18 1/8"-19 3/8"	33023	19	20	189	86
MP-XL	19 3/8"-20 3/8"	33024	19	20	196	89
	20 3/8"-21 1/2"	33025	20	21	204	92.5
	21"-22 5/8"	33032	21	22	212	96
	22 5/8"-23 3/4"	33033	22	23	220	100
	23 3/4"-24 7/8"	33034	23	24	228	103.5
	24 7/8"-26"	33035	24	25	236	107
	26"- 27 1/8"	33036	25	26	244	110.5
	29 3/8"-30 1/2"	33039	28	29	336	152.5

Type T Safety Clamp

Type T Safety Clamp is designed for small diameter pipe 1-1/8 thru 4-1/2 inch OD. Each link changes the effective working range approximately 1 inch in diameter. For size larger than 4-1/2 inch OD, the Type C Safety Clamp should be used.



Total No. links required per range	Range OD Size		P/N
	From	To	
4	1-1/8	2	7624-5044
5	2-1/8	3-1/4	7624-5045
6	3-1/4	4-1/2	7624-5046

Type C Safety Clamp



Item No.	Item	No. REQ'D	P/N
1	Link Assy, complete	As ordered	7624-B-7
2	Link, Intermediate	1	7624-A-18
3	Slip with Cotter	1	7624-A-21
3A	Cotter, for slips (1/4")	1	900620-52
4	Slip Spring	1	7624-B-21
5*	Link pin with cotter	1	7624-C-5
5A"	Cotter, for link (3/16")	1	900620-36
6	End link (Screw)	1	7624-A-20
7	End link (Pivot Block)	1	7624-A-19
8*	End link pin with Chain	1	7624-F-5
9*	Screw	1	7624-A-5
10*	Nut	1	7624-B-5
11*	Nut wrench	1	7624-A-25
12*	Pivot Block	1	7624-A-5000
13*	Pivot Block Pin	2	7624-D-5
14*	Pivot Block pin wrench	1	900533-12
15*	Handle	1	7624-A-6
16*	Handle link pin w/ Cotter	2	7624-G-5
25*	Equipment Box	1	7624-A-9

Total No links	Range OD sizes		P/N
	From	To	
Type CR (Single Screw)			
7*	3 3/4	4 5/8	7624-5007
8	4 1/2	5 5/8	7624-5008
9	5 1/2	6 5/8	7624-5009
10	6 1/2	7 5/8	7624-5010
11	7 1/2	8 5/8	7624-5011
12	8 1/2	9 5/8	7624-5012
13	Feb-91	10 5/8	7624-5013
Type CL (Single Screw)			
14	10 1/2	11 5/8	7624-5014
15	11 1/2	12 5/8	7624-5015
16	12 1/2	13 5/8	7624-5016
17	13 1/2	14 5/8	7624-5017
18	14 1/2	15 5/8	7624-5018
Type CXL (Double Screw)			
18	15 1/2	17	7624-5029
19	16 1/2	18	7624-5030
20	17 1/2	19	7624-5031
21	18 1/2	20	7624-5032
22	19 1/2	21	7624-5033
*7-Slip clamp only carries one handle; all other type CR and CL clamps with handles carry two handles, except CXL, which carries four handles per complete clamp.			

Air Elevator & Spider



Varco designs



BJ Designs



BJ Designs

Slip type elevator/spider are mechanized tools with air operating. They can handle casing up to 24-1/2". They are easy to operate and dependable enough. Also, they can reduce the workload. They are designed and manufactured accordingly API spec 8C standard.

All pneumatically controlled units operated by utilizing the rig air supply. For maximum crew safety, the system may be manually operated if rig air pressure is temporarily lost. Further safety is insured by a positive locking mechanism, which locks slips in the set position.

Casing Size (In)	350 Ton Capacity			500 Ton Capacity		
	Slip set P/N	Insert Set P/N	Qty Insert	Slip Set P/N	Insert Set P/N	Qty Insert
6 5/8	11861	2632-24B-36	60	13841-3	2632-24B-48	72
7	11860	2623-24B-36	60	13841-2	2623-24B-48	72
7 5/8	11859	2633-60	60	13841-1	2633-72	72
8 5/8	11857	2640-32B-48	80	13840-3	2640-32B-64	96
9 5/8	11856	2633-80	80	13840-1	2633-96	96
9 7/8	71591-1	2649-80	80	13840-2	2649-96	96
10 3/4	11854	2640-40B-60	100	13839-3	2640-40B-80	120
10 7/8	71590-1	2650-40B-60	100	13839-4	2650-40B-80	120
11 3/4	11853	2637-100	100	13839-2	2637-120	120
13 3/8	70732-5	2636-40B-60	100	70734-5	2636-40B-80	120
13 1/2	70732-4	2652-40B-60	100	70734-4	2652-40B-80	120
13 5/8	70732-3	2653-40B-60	100	70734-3	2636-40B-80	120
14	70732-1	2635-100	100	70734-1	2635-120	120
16				15790-4	2635-180	180
18 5/8				15790-3	13868-420	420
20				15790-2	1635-180	180
24				15790-1	1635-180	180



SE750, 750 tons air elevator/Spider is available, size range: 4-1/2"~14"

Flush Mounted Spider



Flush Mounted Spider load capacity is 500 tons, size range is 4-1/2"~14".

Air Safety Spinning Wrench



Air safety spinning wrench is a pneumatically powered tool for spinning drill pipe from 3-1/2 to 5-1/2 inch OD. Using the proven principal of frictional drive contact, the spinning wrench can spin drill pipe in or out quickly and efficiently without damage to expensive drill pipe and without the hazards of the dangerous spinning chain.

Model		Q250	Q200
Size Range	mm	88.9~254	88.9~139.7
	in	3-1/2~10	3-1/2~5-1/2
Air Pressures	Mpa	0.5~0.9	0.5~0.9
	psi	72~130	72~130
Rated Power	KW	12	8.8
	HP	16	12
Spinning Speed	RPM	108~38	90~56
Overall Dimension	mm	1250*570*465	1400*530*835
	in	49*23*18	55*21*33
Spinning Torque	lb.ft	403~922	465~738
Spinning Speed	rpm	108~38	90~56
Braking Torque	lb.ft	806~1,844	929~1,475
Air consumption	GPM	3,962	2,721

Hydraulic Spinning Wrench



Model		Q254-300Y
Size Range	mm	88.9~254
	in	3-1/2~10
Spinning Speed	RPM	0~95

Kelly Spinner



Kelly spinner is used for rotating drill pipe slowly, for limited rat hole and mouse hole drilling, and for making fast Kelly connections. This unit is completely reversible, the driller can spin out, as well as spin in, and when making

connection, therefore, spinning chains are not required any more.

Kelly Spinner		FXD	QF2	Q3
Max.Static Load	US Ton	250	250	250
Air Pressures	Mpa	0.5~0.9	0.5~0.9	0.5~0.9
	psi	72~130	72~130	72~130
Rated Torque	lb.ft	882	1180	1217
Braking Torque	lb.ft	1100	1844	1844
Spinning Speed	rpm	76	72	72
Spinning Direction		Single	Double	Double
Conn.		6 5/8 Reg. LH	6 5/8 Reg LH	6 5/8 Reg. LH
Overall Dimensions	in	33*29*28	22*22*37	34*28*39

Tubulars and Drilling String



We provide a variety seamless and welded petroleum industry tubulars per the quality standards of :

API 5CT API 5B API 5DP API 5L ISO

1. Casing

Size: 4-1/2" to 30"

Grade: J55, K55, N80, L80, C90, C95, P110, Q125, V150

Connection: BTC, STC, LTC and Premium connection, such like: VAM, TPCQ, Hydrill connections, etc...

Length: R1, R2, R3

2. Tubing

Size: 2-3/8" to 4-1/2"

Grade: J55, N80, L80, C90, T95, P110

Connection: 8RD and Premium connection, such like: VAM, TPCQ, Hydrill connections, etc...

Length: R1, R2, R3

Type of finish: NU (Non Upset), EU (External Upset), IEU (Internal and External Upset).

3. Heavy Weight Drill Pipe (HWDP)

Size: 2-7/8", 3-1/2", 4", 4-1/2", 5", 5-1/2", 6-5/8".

Length: 31ft

Others: Internal coating and hardbanding is available per clients' requirement.

4. Drill Pipe

Size: 2-3/8", 2-7/8", 3-1/2", 4", 4-1/2", 5", 5-1/2", 6-5/8"; Grade: E, X, G, S ; Length: R1, R2 and R3.

Upset type: NU (Non Upset), EU (External Upset), IEU (Internal and External Upset).

Others:

(1). Internal coating and hardbanding is available per clients' requirement.

(2). We can provide high strength, Sour service and double shoulder drill pipes per client's requirement.

5. Drill Collar

Size: 3-1/8", 4-1/8", 4-3/4", 5", 6", 6-1/4", 6-1/2", 6-3/4", 7", 7-1/4", 8", 8-1/4", 9", 9-1/2", 9-3/4", 10", 11".

Length: 9150mm, 9450mm.

Others:

- (1) Internal coating and hardbanding is available per clients' requirement.
- (2) Slick drill collar and Spiral drill collar is available.
- (3) NMDC (Non Magnetic drill collar) is available.



6. Kelly

Size: 2-1/2", 3", 3-1/2", 4-1/4", 5-1/4", 6".

Type: Square Kelly and Hex Kelly.

Length: 40ft, 46ft, 54ft.

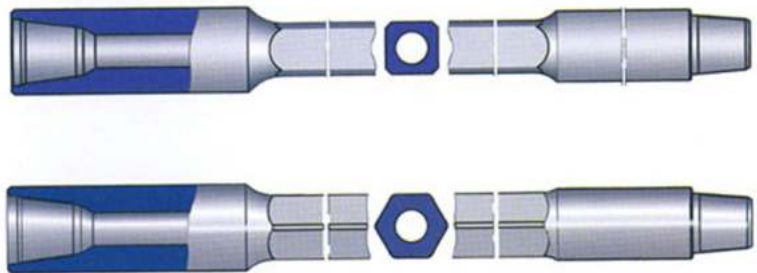

7. Pup Joints

We supply full ranges pup joints for casing, tubing, drill pipe, drill collar.

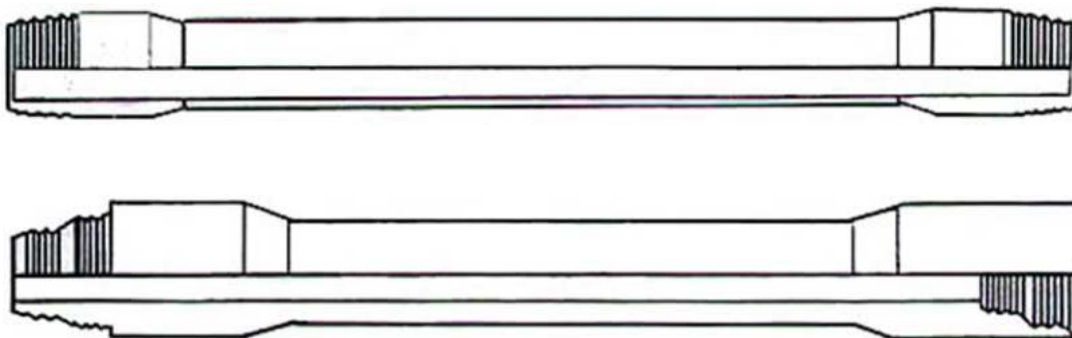

8. Others

Couplings, Flanges, Elbows, Tees, X-Overs, Lifting nubbins, Lifting caps, Gasket, Bolts and nuts, etc.



9. Sucker Rod

Sucker rod conforms to API Specification 11B (Oil extraction rod Standard) and other related standards, authorized to use the API monogram.

Grade: C, D, K, KD, HL, HY

Name	API Standard	API Nominal Dia	API Length	Weight (kg/pc)
Sucker rod	Grade D Grade C Grade K	3/4inch(19mm)	25feet(7620mm)	18.38
			30ft(9140mm)	21.77
		7/8inch(22mm)	25feet(7620mm)	24.51
			30feet(9140mm)	29.04
		1inch(25mm)	25feet(7620mm)	32.36
			30feet(9140mm)	38.21
Coupling	Grade SM Grade T	3/4inch(19mm)	4inch(101.6mm)	0.61
		7/8inch(22mm)	4inch(101.6mm)	0.78
		1inch(25mm)	4inch(101.6mm)	1.17



10. Drill Bit

PDC bit



Rock bit



PDC bits and Rock bits are designed and manufactured per API standard.

Integral Mandrel Sleeve Stabilizers



Integral mandrel sleeve stabilizers are made in two parts: One mandrel and one sleeve. The assembled by screwing the sleeve on the body and tightening these on the shoulder. The sleeve has been engineered to avoid any accidental unscrewing as to be easily replaced on rig. integral mandrel sleeve stabilizers are made in two parts: One mandrel and one sleeve. The assembled by screwing the sleeve on the body and tightening these on the shoulder. The sleeve has been engineered to avoid any accidental unscrewing as to be easily replaced on rig.

WORKING OD	FISHING OD	UP CONN.	DOWN CONN.	I.D.	FISHING LENGTH	OAL
inch (mm)	inch (mm)			inch (mm)	inch (mm)	inch (mm)
28 (711.2)	9-1/2 (241.3)	7-5/8REG	7-5/8REG	3 (76.2)	27 (686)	78 (1981)
26 (660.4)	9-1/2 (241.3)	7-5/8REG	7-5/8REG	3 (76.2)	26 (660)	76 (1930)
22 (558.8)	9-1/2 (241.3)	7-5/8REG	7-5/8REG	3 (76.2)	26 (660)	76 (1930)
17-1/2 (444.5)	9-1/2 (241.3)	7-5/8REG	7-5/8REG	3 (76.2)	27 (686)	67 (1702)
12-1/4 (311.1)	8 (203.2)	6-5/8REG	6-5/8REG	2-13/16 (71.4)	24 (610)	61 (1550)
8-1/2 (215.9)	6-1/2 (165.1)	NC50	4-1/2REG	2-13/16 (71.4)	27 (686)	66 (1676)
6 (152.4)	4-3/4 (120.7)	NC38	3-1/2REG	2 (50.8)	27 (686)	58 (1473)
5-7/8 (149.2)	4-3/4 (120.7)	NC38	3-1/2REG	2 (50.8)	22 (559)	54 (1372)

Integral Spiral Blade Type Stabilizer

Integral Spiral Blade Stabilizers is divided into string type and near-bit type according to the position differently, there are many ways to increasing abrasive resistance, eg. tungsten carbide, it owns high hardness, great toughness, high resistance and long service life.



WORKING OD	FISHING OD	UP CONN.	DOWN CONN.	ID	OAL	FISHING LENGTH	BLADE LENGTH	BLADE WIDE
inch (mm)	inch (mm)	inch (mm)		inch (mm)	inch (mm)	inch (mm)	inch (mm)	inch (mm)
5-7/8 (142.9)	4-3/4 (120.7)	NC38	NC38 (3-1/2REG)	2-1/4 (57.2)	57 (1448)	20 (508)	16 (406)	2-1/4 (57.2)
8-1/2 (215.9)	6-1/2 (165.1)	NC50	NC50 (4-1/2REG)	2-13/16 (71.4)	60 (1524)	20 (508)	16 (406)	2-1/2 (63.5)
12-1/4 (311.1)	8 (203.2)	6-5/8REG		2-13/16 (71.4)	63(1600)	20 (508)	16 (406)	3-1/2 (89)
17-1/2 (444.5)	9 (228.6)	7-5/8REG		3 (76.2)	72 1/2 (1840)	20 (508)	18 (457)	4-3/4 (121)
22 (558.8)	9-1/2 (241.3)	7-5/8REG		3 (76.2)	93 (2362)	30 (762)	20 (508)	4-3/4 (121)

Releasing and Circulating Overshot

The releasing and circulating overshot is simple and rugged and is strongest tool available to externally engage, pack off and pull a fish.

The internal catch mechanisms are of two basic types: a basket grapple and a spiral grapple. According to different uses, it may be equipped with some accessories, such as extension sub, wall hook, enlarged guide, etc.



Type	O.D. (mm/inch)	Max. Catch Size (mm/inch)		Connection API
		Basket Grapple	Spiral grapple	
LT102	102(4)	57.2(2-1/4)	70(2-3/4)	NC26
LT111	111(3-3/4)	60.3(2-3/8)	76.2(3)	NC31
LT133	133(5-1/4)	95.3(3-3/4)	101.6(4)	NC38
LT146	146(5-3/4)	101.6(4)	119.4(4-11/16)	NC38
LT206	206.4(8-1/8)	146(5-3/4)	168(6-5/8)	NC50
LT245	245(9-5/8)	184.2(7-1/4)	203(8)	6-5/8RGE
LT270	269.9(10-5/8)	200(7-7/8)	220(8-21/32)	6-5/8RGE
LT286	285.8(11-1/4)	203(8)	245(9-41/64)	6-5/8RGE
LT340	340(13-3/8)	222(8-3/4)	267(10-1/2)	6-5/8RGE

Mud Saver Bucket



During the pulling of wet strings of drill pipe, the saver helps to prevent the unnecessary loss of costly drilling fluids and helps maintain a safer, cleaner work area.

This tool features quick-opening and closing latch assembly that provides an easy, quick operation. Its special sealing rubber can be easily replaced whenever necessary. The saver is equipped with a threaded side coupling. Operator can connect the coupling to the shaker pit with a hose. When the drill pipe is disconnected, the fluid will flow into the pit directly.

Specifications: 2-3/8", 2-7/8", 3-1/2", 4", 5", 5-1/2".

Reverse Circulation Junk Basket

The reverse circulation junk basket is used to retrieve all types of small junk objects in well bores. Such as bit cones, cutting blades and hand tools, etc..

During operation, with the steel ball dropped into the valve seat, fluid flow in a continuous stream to the center of the tool and up through return ports in the upper end of the barrel, all junk is thus carried into the barrel above the junk catcher.

Type	Max. O.D. (mm/inch)	Steel Ball O.D (mm/inch)	Connection API	Hole Size Range (mm/inch)	OAL (mm/inch)
LL146	151(5-15/16)	35(1-3/8)	NC38	155.6~165.1(6-1/8~6-1/2)	1376(54-11/64)
LL200	205(5-5/64)	43(1-11/16)	NC50	212.7~241.3(6-1/8~6-1/2)	1766 (69-17/32)
LL257	257(10-1/8)	48(1-57/64)	6-5/8REG	273~295.3(10-3/4~11-5/8)	1770 (69-11/16)
LL280	286(11-1/4)	48(1-57/64)	6-5/8REG	298.5~311.2(11-3/4~12-1/4)	1846(72-43/64)
LL381	381(15)	60(2-23/64)	7-5/8REG	406.4~444.5(16~17-1/2)	1780(70-5/64)



Other Fishing & Down Hole Tools



Reversing Spears



Reversing Circulation Fishing Magnet



Junk Sub



X-Over Sub

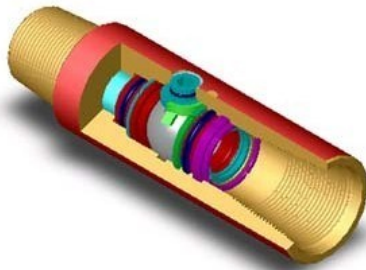

Kelly Valve



Float Valve Sub



Drilling Jar

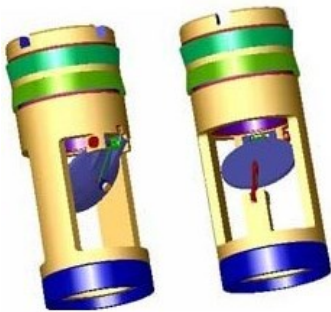

Float Valve



Casing Scraper



Reamer



Downhole Motor



Hole Opener

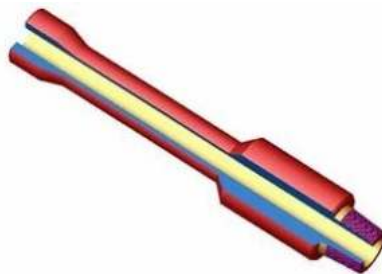

Lifting Sub

We provide a comprehensive downhole tools and fishing tools, The tools are manufactured and inspected according to applicable API and ISO standards.

Other Tools and Accessories



Integral Fittings



Loops, High Pressure Straight Pipe



Swivel Joints



Air Winch

Model	Capacity
QJC0.5	0.5 ton
QJC1.0	1 ton
QJC3.0	3 ton
QJC5.0	5 ton
QJC8.0	8 tons
QJC10	10 tons



API Drilling Line



High Pressure Hose up to
20,000psi WP

Headquarter, United Kingdom

SMARTECH OILFIELD EQUIPMENTS & SPARE PARTS
TRADING LIMITED
71-75 Shelton Street, London, Greater London,
WC2H 9JQ, UNITED KINGDOM
+44 20710 13287
info@smartech.uk
www.smartech.uk

UAE Office

SMARTECH OILFIELD EQUIPMENTS & SPARE PARTS
TRADING LLC
Al Quoz 3, DUBAI, UNITED ARAB EMIRATES,
PO BOX-38312
+971-4-3806770
info@smartechdubai.com
www.smartechdubai.com

Goetze KG Armaturen

Robert-Mayer-Strasse 21
D-71636 Ludwigsburg
GERMANY
Authorized Distributor of Middle East
www.goetze-armaturen.com

China Office

KINGRIG OILFIELD & OFFSHORE SOLUTIONS
Kunshan, Jiangsu, CHINA
+86-512-36822085
www.kingrig-oilman.com

India Office & Manufacturing Facility

PI CONTROLS INSTRUMENTS PVT LTD
100 Shed Area, Vapi
Valsad, Gujarat, INDIA
www.picontrols.co.in

